



Intergovernmental
Oceanographic
Commission

Manuals and Guides 17



A GENERAL FORMATTING SYSTEM
FOR GEO-REFERENCED DATA

VOLUME 2

TECHNICAL DESCRIPTION OF THE GF3 FORMAT
AND CODE TABLES

1987 Unesco

PREFACE

The General Format 3 (GF3) system was developed by the IOC Working Committee on International Oceanographic Data Exchange (IODE) as a generalized formatting system for the exchange and archival of data within the international oceanographic community. It was presented to the Ninth Session of the Working Committee (New York, 15-19 January 1979) which recommended that GF3 "be adopted for general use in international oceanographic data exchange" and "urged Member States to utilize GF3 as the standard international exchange format". This recommendation was subsequently endorsed by the IOC Executive Council at its Eleventh Session (Mexico City, 1-3 March, 1979). The Executive Council also approved the establishment of a Group of Experts on Format Development to keep the format under review, to develop the parameter code system and standard discipline-orientated subsets, and to provide advice and guidance in the use of GF3.

It should be noted that, following the decisions of the Fourteenth Session of the IOC Assembly in March 1987, the IOC Working Committee on IODE is now renamed the IOC Technical Committee on International Oceanographic Data and Information Exchange, retaining the acronym IODE, and the IODE Group of Experts on Format Development is renamed the IODE Group of Experts on Technical Aspects of Data Exchange, and these names are used hereafter.

Support services in the use of GF3 are provided by the Service Hydrographique of the International Council for the Exploration of the Sea (ICES), acting as the Responsible National Oceanographic Data Centre for Formats, RNODC (Formats). The ICES Service Hydrographique is assisted in this task by the Marine Information and Advisory Service (MIAS) of the United Kingdom which provides technical advice and guidance on the use of GF3 and its supporting software.

The RNODC (Formats) operates under the following Terms of Reference:

- i) To act as an archive centre for international marine environmental data formats, maintaining a full set of documentation on all such formats.
- ii) To act as an archive centre for the code tables for GF3 and the code tables for all other international oceanographic archival formats, and for external code tables (e.g. taxonomic codes, chemical substances codes, etc), maintaining references to all such code tables.
- iii) To manage the expansion of the existing GF3 parameter code table as necessary under the guidance of the IOC Technical Committee on International Oceanographic Data and Information Exchange (through its Group of Experts on Technical Aspects of Data Exchange), and to provide a focal point to which user requirements for new parameter codes may be directed.
- iv) To maintain user aids for GF3, including a programme library for the processing of GF3, guidance notes and user guides, documentation of standard and experimental subsets of GF3, and sample data tapes of GF3 subsets.
- v) To function as a centre for services to other centres in IOC and ICES Member States in such GF3 matters as responses to requests for information about, or copies of, items in i) to iv) above.

- vi) To prepare a report to the IOC Technical Committee on IODE, together with a Newsletter for distribution to National Coordinators for IODE, National Oceanographic Data Centres and other interested parties such as WMO, ECOR, SCOR, highlighting new developments in GF3 and including an updated inventory of the documents, programmes, tapes, formats and code tables available.

- vii) To work closely with the Group of Experts on Technical Aspects of Data Exchange to ensure the provision of expert knowledge on formats to other centres including World Data Centres-A and -B (all disciplines) and subsidiary bodies of WMO, IOC and other international organizations and in the promotion of GF3 as an exchange format. The provision of expert knowledge will be ensured in fields covering:
 - a) guidance in the uses of GF3;
 - b) assistance to developing countries, including the development of national formats compatible with GF3;
 - c) assistance to developing data centres and countries, in collaboration with other RNODCS, in converting data into GF3.

Enquiries concerning these services should be addressed to:

RNODC (Formats),
ICES Service Hydrographique,
Palaegade 2-4,
DK-1261 Copenhagen K,
DENMARK.

Requests for technical advice and guidance on the use of GF3 should be addressed to

Marine Information and Advisory Service,
Institute of Oceanographic Sciences,
Bidston Observatory,
Birkenhead, Merseyside, L43 7RA
UNITED KINGDOM.

The IOC is prepared to make the GF3-Proc software package (see Foreword) freely available on magnetic tape to all organizations or laboratories involved in the international collection, management or exchange of oceanographic and other earth sciences data. Technical support for the distribution, installation and maintenance of GF3-Proc is provided, on behalf of the IOC, by MIAS. Requests for copies of GF3-Proc should be forwarded to MIAS at the address above and should include a clear description of the computer system on which it is to be installed, including the manufacturer, make and model number of the machine, the name and version of the operating system and an identification of the Fortran compiler. A small charge may be made to cover the cost of the tape and its documentation.

FOREWORD

General Format 3 (GF3) is a system for formatting geo-scientific data series into sequential files on digital storage devices. It is not a fixed format in the conventional sense but is a generalized system which allows the user a number of ways of organizing his data such that whichever way he chooses, the data fit into GF3. Provision is made in GF3 for the user to describe, in the same files that carry the data, the exact format he has selected and all codes he has used, as well as ample space for plain language documentation.

Although GF3 was developed originally as a formatting standard for data exchange purposes, it is equally well suited for use in the archiving of data. It is a highly versatile system capable of accommodating virtually any type of digital oceanographic data including physical, chemical, biological, geological, geophysical and meteorological measurements. Being multi-disciplinary in nature it is also applicable to other branches of the environmental and geo-sciences outside the field of oceanography. The main requirement for data series to be included in GF3 is that they are digital and are referenced in a space-time framework based on geographic coordinates. Using GF3, diverse data types may be integrated into the same storage system. When used with homogeneous data sets, GF3 has the particular advantage of allowing adjustments to be made to the storage format as data collection techniques evolve or as new parameters are added to the data set.

The routine collection of geo-scientific data is often geared towards rather specific types of measurements. Occasions will therefore arise when the full flexibility of the GF3 system is not required and where the user may prefer a format tailored specifically to a particular type of data. GF3 is well suited for this purpose in that it provides a framework within which data specific standard formats can be created. Such formats can be considered as subsets of the GF3 formatting system. A standard subset may be constructed simply by pre-selecting the use of the various options within GF3, and in particular by pre-defining the user-definable aspects of the format. In this manner, GF3 may be tailored specifically to standard types of data as and when required.

Data can be stored and retrieved in GF3 with simple rather short programs. The GF3 system includes a Fortran-based software package, GF3-Proc, to facilitate the reading and writing of data in GF3. The package is designed as a suite of Fortran sub-routines and provides a complete software interface to GF3 enabling the user to handle GF3 in an automated fashion. It is also designed to be portable between different computer systems so as to be readily available to scientists and data centres alike.

The documentation for the GF3 system is published in IOC Manuals and Guides No. 17 in five separate volumes under the title 'GF3 - A General Formatting System for Geo-Referenced Data'.

Volume 1 : 'Introductory Guide to the GF3 Formatting System' is intended to familiarize the new user with the purpose and scope of the GF3 system without overburdening him with technical detail. An introduction is provided, both to the GF3 format and to its supporting software package GF3-Proc.

Volume 2 (this volume) : 'Technical Description of the GF3 Format and Code Tables' contains a detailed technical specification of the GF3 format and its associated code tables.

Volume 3 : 'Standard Subsets of the GF3 Format' contains a description of standard subsets of the GF3 format tailored to a range of different types of data. It also serves as a set of worked-up examples illustrating how the GF3 format may be used.

Volume 4 : 'Users' Guide to the GF3-Proc Software' provides an overview of GF3-Proc explaining what it does, how it works and how it is used. It also provides an introduction to the subroutine calls in the user interface to the package.

Volume 5 : 'Reference Manual for the GF3-Proc Software' contains a detailed specification of each GF3-Proc subroutine callable from the user's program and provides detailed instruction on how and when these routines may be used.

ACKNOWLEDGEMENTS

The design and technical specification of the GF3 format were prepared by Meirion T. Jones of the UK Marine Information and Advisory Service of the Institute of Oceanographic Sciences, working in close collaboration with the IODE Group of Experts on Technical Aspects of Data Exchange.

The design, coding and testing of the GF3-Proc software is the result of the combined efforts of two computer experts, Roy K. Lowry and Trevor Sankey of the UK Marine Information and Advisory Service. It involved approximately 15 man-months of effort over a two-year period between 1983 and 1985. The work was carried out under the direction of Meirion T. Jones and in close collaboration with the IODE Group of Experts on Technical Aspects of Data Exchange.

CONTENTS

	Page
SECTION 1: INTRODUCTION	
1.1 Introduction to GF3	1
1.2 Technical Specification of GF3	2
1.3 The GF3 Code Tables	2
SECTION 2: THE STRUCTURE OF GF3 TAPES	
2.1 General Characteristics	3
2.2 GF3 Files	5
2.3 GF3 Records	6
SECTION 3: THE SEQUENCING OF GF3 RECORDS	
3.1 General Rules	7
3.2 Rules of Precedence for Definition Records	9
3.3 Record Sequencing within Individual Files	10
SECTION 4: THE CONTENT AND FORMAT OF GF3 RECORDS	
4.1 General Rules	11
4.2 Test Record	12
4.3 Plain Language Record	13
4.4 Tape Header Record	15
4.5 File/Series Header Record	18
4.6 Data Cycle Record	25
4.7 End of Tape Record	27
SECTION 5: THE DEFINITION RECORD AND THE 'USER-DEFINED AREAS' OF GF3 RECORDS	
5.1 The Use of Definition Records	29
5.1.1 General Principles	29
5.1.2 Data Cycle Definition Records	30
5.1.3 Series Header Definition Records	31
5.2 The Format and Content of Definition Records	31
5.2.1 Series Header/Data Cycle Definition Record Specification	32
5.2.2 Fortran Format Statement	35
5.2.3 Fortran Format Types	38
5.2.4 Scaling Factors	39
5.2.5 Dummy Value Code	40
5.2.6 Parameter Discriminator	41
5.2.7 Parameter Attributes	41
ANNEX I GF3 CODE TABLE 1: IOC COUNTRY CODE	
ANNEX II GF3 CODE TABLE 2: GF3 COMMON CHARACTER SET	
ANNEX III GF3 CODE TABLE 3: PLATFORM TYPE CODE	
ANNEX IV GF3 CODE TABLE 4: SPECIFIC PLATFORM CODE	
ANNEX V GF3 CODE TABLE 5: MODIFIED I.H.B. OCEAN/SEA AREA CODE	
ANNEX VI GF3 CODE TABLE 6: VALIDATION FLAG	
ANNEX VII GF3 CODE TABLE 7: PARAMETER CODE	
ANNEX VIII INDEX TO PARAMETER CODE ORDERED BY CODE	
ANNEX IX INDEX TO PARAMETER CODE ORDERED BY DIMENSION EXPONENTS	
ANNEX X WMO CODE TABLES	

SECTION 1

INTRODUCTION

1.1 INTRODUCTION TO GF3

GF3 is a character oriented format and may be used on any digital storage device supporting sequential files. Although designed originally for use with conventional magnetic tapes, it may be easily adopted for use with other digital storage media such as, for example, Winchester disks, floppy disks, optical disks and tape cassette mass storage devices. However it should be noted that the Technical Specification contained in the present volume does not address the direct access features of these other media i.e. the ability to directly access a specific data file without having to pass in sequence through all preceding files as is required with magnetic tape. The Technical Specification represents the standard that should be adhered to in preparing GF3 magnetic tapes for the purpose of data exchange. Thus all data files are arranged in sequence on the tape but are preceded at the beginning of the tape by a Test File and a Tape Header File, and the tape ends with a Tape Terminator File. These additional tape related files are used primarily for administrative and labelling purposes, although the Tape Header File may also be used to store information that is common to the various data files on the tape.

The tape specific features of the Technical Specification need not affect the data files in which the actual data are stored. It is a feature of the GF3 system that each data file within a data set is completely independent of other data files and may be constructed as a totally self-contained entity. GF3 data files may therefore be stored on direct access media such that individual data files may be accessed directly. In such cases, each file should always be processed as a sequential file starting at the beginning of the file. All records in the file must be sequenced, organised and formatted according to the GF3 specifications.

The underlying structure of the GF3 system is built around logical records of a fixed length of 1920 bytes and all relevant data and information are stored in these records in character coded format. The records provide the building units from which GF3 data sets are constructed. There are a number of different types of GF3 record, each with its own distinctive use and format. A proper understanding of the GF3 system requires knowledge of the usage and contents of these records. Thus, for example, there are header records to define the beginning of a GF3 file or series, plain language records for the textual information necessary to qualify and document the stored data, and data cycle records which may be used for the storage of data. However, the key to the GF3 system is the GF3 definition record which is used to define the content and format of the stored data. The definition record makes possible the automatic processing features of GF3 and can be interpreted by computer to determine what parameters are contained in the data set, where they are located in the records, what units they are in and in what format they are stored.

The flexibility of GF3 results from the variety and number of possible usages and combinations of the GF3 record types. This makes it possible to include within the format scheme structures from the very simple to those with several layers of hierarchy.

1.2 TECHNICAL SPECIFICATION OF GF3

The Technical Specification of GF3, as presented in this volume, commences with a description of a GF3 magnetic tape in terms of its files, followed by an explanation of the build up of the files themselves from the allowed record types. A detailed specification is then given of the format and content of the fixed, i.e. predefined, elements of each GF3 record. It concludes with a detailed description of the GF3 Definition Record showing how it is used to specify the 'user-defined' elements of the format.

The Technical Specification is arranged in four sections as follows:

Section 2: 'The Structure of GF3 Tapes' specifies the recording characteristics that should be adhered to in preparing a GF3 magnetic tape for exchange purposes. It also describes the four different types of GF3 file that are used to create a GF3 tape and concludes with a description of the various GF3 records used in the construction of GF3 files.

Section 3: 'The Sequencing of GF3 Records' presents the rules for sequencing and organising GF3 records into files and shows how the individual files are constructed.

Section 4: 'The Content and Format of GF3 Records' provides a detailed specification of those GF3 records and record areas that are of a fixed predefined content and format. General guidelines are presented concerning the layout of GF3 records, and the content and format of each GF3 record type is then described in detail in terms of its constituent fields.

Section 5: 'The Definition Record and the User-Defined Areas of GF3 Records' describes the format and content of the GF3 Definition Record and explains how it is used to define the format and content of the data areas, i.e. 'user-defined areas', of GF3's Series Header Record and Data Cycle Record. These two records provide the main areas in the GF3 format where actual data are stored.

1.3 THE GF3 CODE TABLES

There are seven code tables used in support of the GF3 format and these are to be found in the annexes at the end of this volume thus:

Annex I GF3 Code Table 1: 'IOC Country Code' - to identify the country of the institution responsible either for the original collection of the data or for preparing it in GF3 format.

Annex II GF3 Code Table 2: 'The GF3 Character Set' - lists the set of characters allowed in GF3 records, together with their ASCII and EBCDIC equivalents.

Annex III GF3 Code Table 3: 'Platform Type Code' - for identifying the type of platform from which the data were collected.

Annex IV GF3 Code Table 4: 'Specific Platform Code' - for identifying the specific platform from which the data were collected.

Annex V GF3 Code Table 5: 'Modified IHB Ocean/Sea Area Code' - to identify the geographic area within which the data were collected.

Annex VI GF3 Code Table 6: 'Validation Flag' - a one character quality control flag.

Annex VII GF3 Code Table 7: 'Parameter Code' - for identifying the parameters (or variables) stored in the data areas of GF3 records.

SECTION 2

THE STRUCTURE OF GF3 TAPES

GF3 tapes are character orientated digital magnetic tapes. The information carried on a tape is contained in the most basic element of the structure, the GF3 record. Records are organised into files according to the rules of GF3 and files are organised into tapes. This Section specifies the general characteristics of a GF3 tape and describes the four different types of file that are used to create a GF3 tape. It concludes with a description of the various types of GF3 record used in the construction of GF3 files. The rules for sequencing GF3 records into files are given in Section 3.

2.1 GENERAL CHARACTERISTICS

2.1.1 GF3 Character Set - In order to maximise the utility of GF3 for data exchange purposes, only a restricted set of characters are allowed on a GF3 tape. These are the upper case letters A to Z, the decimal numerals 0 to 9, the blank character and the special characters:

+ - * / > < = . , : ; ()

(By agreement between exchanging parties the lower case letters a to z may be used in the plain language text areas of certain GF3 records - see Annex II for details)

2.1.2 Records - The GF3 system is built around logical records of a fixed length of 1920 bytes - these records are padded out with blanks or nines (9s), where necessary, to make up the length. For data exchange on magnetic tape it is recommended that one logical record is stored per physical block. However, by agreement between exchanging parties, an increased blocking factor (e.g. 4) may be used if tape usage is critical e.g. for high volume data sets.

2.1.3 Tape characteristics - Unless agreed otherwise between exchanging parties, it is recommended that GF3 tapes created for exchange purposes should conform to the following standard:

tape width : 0.5 inch (12.7mm)

reel diameter : 10.5 inches (267mm) maximum

tape length : 2400 foot (732m) maximum

no. of tracks : 9

block size : 1920 bytes (see above)

tape density : 1600 bpi (bytes/inch) - where convenient to the exchanging parties the use of the higher density of 6250 bpi is encouraged

character code : ASCII or EBCDIC - a translation table is built into GF3 for the conversion of other character codes but their use is not encouraged

unlabelled : the tape should not contain label files or physical record labels

Figure 1. GF3 TAPE STRUCTURE

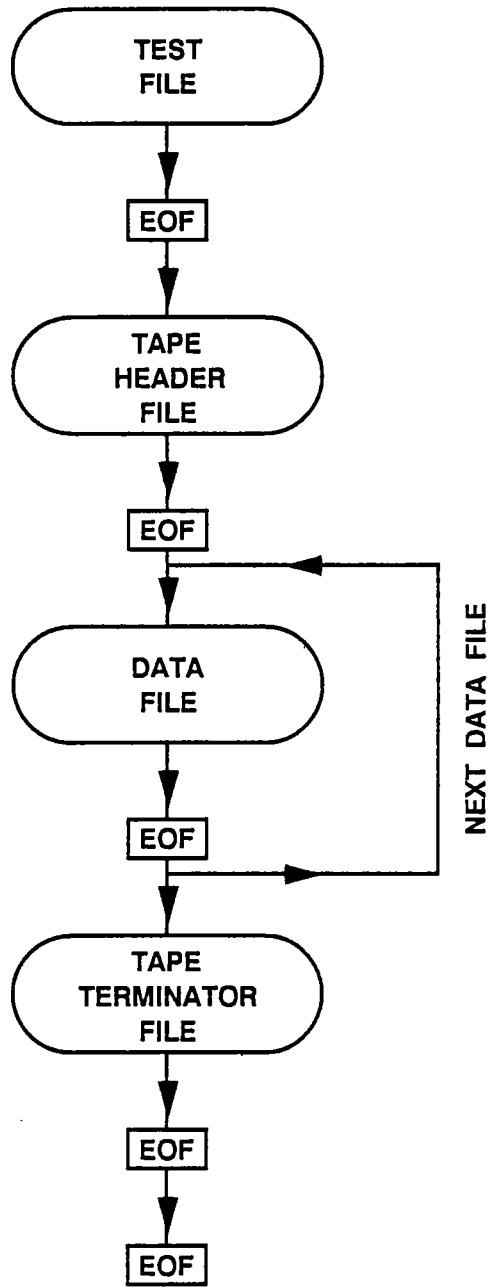

2.2 GF3 FILES

For exchange purposes all GF3 tapes must conform with the basic file layout illustrated in Figure 1. There are four different types of GF3 file:

Test File

Tape Header File

Data File

Tape Terminator File

Each GF3 tape will always contain one and only one test file, tape header file and tape terminator file. There will be one or more data files, as necessary. Each file is terminated by a single End of File (EOF) Mark (sometimes called a tape mark), except for the last file on the tape which is the tape terminator file and which is terminated by two EOF marks.

- 2.2.1 The GF3 'Test File' is the first file on the tape and its primary purpose is to protect the leading portion of the tape's contents from damage. The file consists of sufficient records to occupy about two metres at the beginning of the tape.
- 2.2.2 The GF3 'Tape Header File' will always appear as the second file on the tape. It provides administrative information about the tape and its origin, for example, the originating country and institution, the date the tape was created, the tape number and the version of GF3 used in setting up the tape. It may also contain plain language text overviews of the contents of the tape and describing any code tables or special codes used on the tape. The file may also include formatting information common to the tape as a whole.
- 2.2.3 The GF3 'Data Files' contain the data. These files are constructed using the record types provided by GF3 and may contain one or more data series. Not all the data files on a GF3 tape need have the same structure. For example, a multi-disciplinary dataset from a large experiment might contain physical and biological oceanographic data in some files, meteorological and drifting buoy data in still other files, or indeed a mixture of these. No two data files or data series need necessarily be formatted identically or contain the same parameters. Each file contains all the formatting information necessary to decode it and interpret the data. If all files and series on the tape have the same format and content, the formatting information may be included in the tape header file instead.
- 2.2.4 The GF3 'Tape Terminator File' appears as the last file on the tape and serves to terminate the tape and to indicate the next tape in the dataset, if there is one.

2.3 GF3 RECORDS

The GF3 records are the basic components from which GF3 files are constructed. There are seven different types of logical record in GF3. Each has a fixed length of 1920 bytes but with its own distinctive use and format:

Test Record	File/Series Header Record
Plain Language Record	Data Cycle Record
Tape Header Record	End of Tape Record
Definition Record	

- 2.3.1 The GF3 'Test Record' is used only in the test file at the beginning of a GF3 tape and consists of a character 'A' repeated 1920 times.
- 2.3.2 The GF3 'Plain Language Record' consists of free format textual information and is used to provide information and comments. These records can be inserted at the tape level to provide information pertinent to the whole tape, at the file level to provide information pertinent to a file, and at the series level to provide information on a single series. The liberal use of these records is encouraged in order that the data may be adequately qualified and documented.
- 2.3.3 The GF3 'Tape Header Record' is a fixed format record which is used to provide administrative information about the tape and its source. It appears once only on the tape at the beginning of the tape header file.
- 2.3.4 The GF3 'Definition Record' is the key to the GF3 formatting system. It is used to define the contents of the 'user-defined area' of the Series Header Records and of the Data Cycle Records. The Definition Records can be interpreted by computer to determine what parameters are on the tape, where they are located in the records, what units they are in and in what format they are stored. The Definition Record makes possible the automatic processing features of GF3.
- 2.3.5 The GF3 'File Header' and 'Series Header' Records are used to define the beginning of either a GF3 data file or a GF3 data series. They provide information about the data in the file or series, such as the location of the data in space and time, the platform from which the data were collected and the institution responsible for collecting the data. Most of this information is contained in the first 400 bytes of the record. The File Header Record is a fixed format record. However, only the first 400 bytes of the Series Header Record comprise fixed fields - the remaining 1520 bytes form what is called a 'user-defined area' and contain other data pertaining to the series not provided for in the fixed format area.
- 2.3.6 The GF3 'Data Cycle Record' is used to carry data, as appropriate. The record is entirely user-defined, except for 20 bytes of administrative information.
- 2.3.7 The GF3 'End of Tape Record' is a fixed format record which is used to terminate the tape and to indicate whether the data are continued on another tape. It appears once only on the tape and is the last record on the tape.

SECTION 3

THE SEQUENCING OF GF3 RECORDS

This Section describes the sequencing rules for organising GF3 records and shows how individual GF3 files are constructed.

3.1 GENERAL RULES

The organisation and sequencing of records within a GF3 data set is illustrated in schematic form in Figure 2. Note that certain records are mandatory, i.e. they must be included in the data set in their specified position, while other types of record are optional and are only included if it is appropriate to do so. The sequencing of records may be ascertained by following the flow path in Figure 2, starting at the test record and working through to the end of tape record - skip over the optional records when they are not required but always ensure that any mandatory record encountered is included.

As will be described in Section 4, the first byte of each record contains a code to identify its record type (e.g. '0' = plain language record, '1' = tape header record, etc). The second byte contains the record type identifier of the following record. Thus, in reading a GF3 data set one is always aware of the record type of the following record before it is read in.

Although each type of GF3 file has its own well defined structure of allowable record types, certain general rules apply to the organisation and sequencing of records within a GF3 data set:

3.1.1 The following records are mandatory:

- i) the test file consists solely of test records
- ii) the tape header file will always start with a tape header record
- iii) each data file will always start with a file header record
- iv) each data series will always start with a series header record
- v) the tape terminator file consists solely of a file header record (with dummy entries) followed by an end of tape record

3.1.2 Plain language records and definition records may appear in any number and combination at any of three levels:

- i) at tape level if they apply to the tape as a whole
- ii) at file level if they apply to a specific data file
- iii) at series level if they are specific to a particular data series

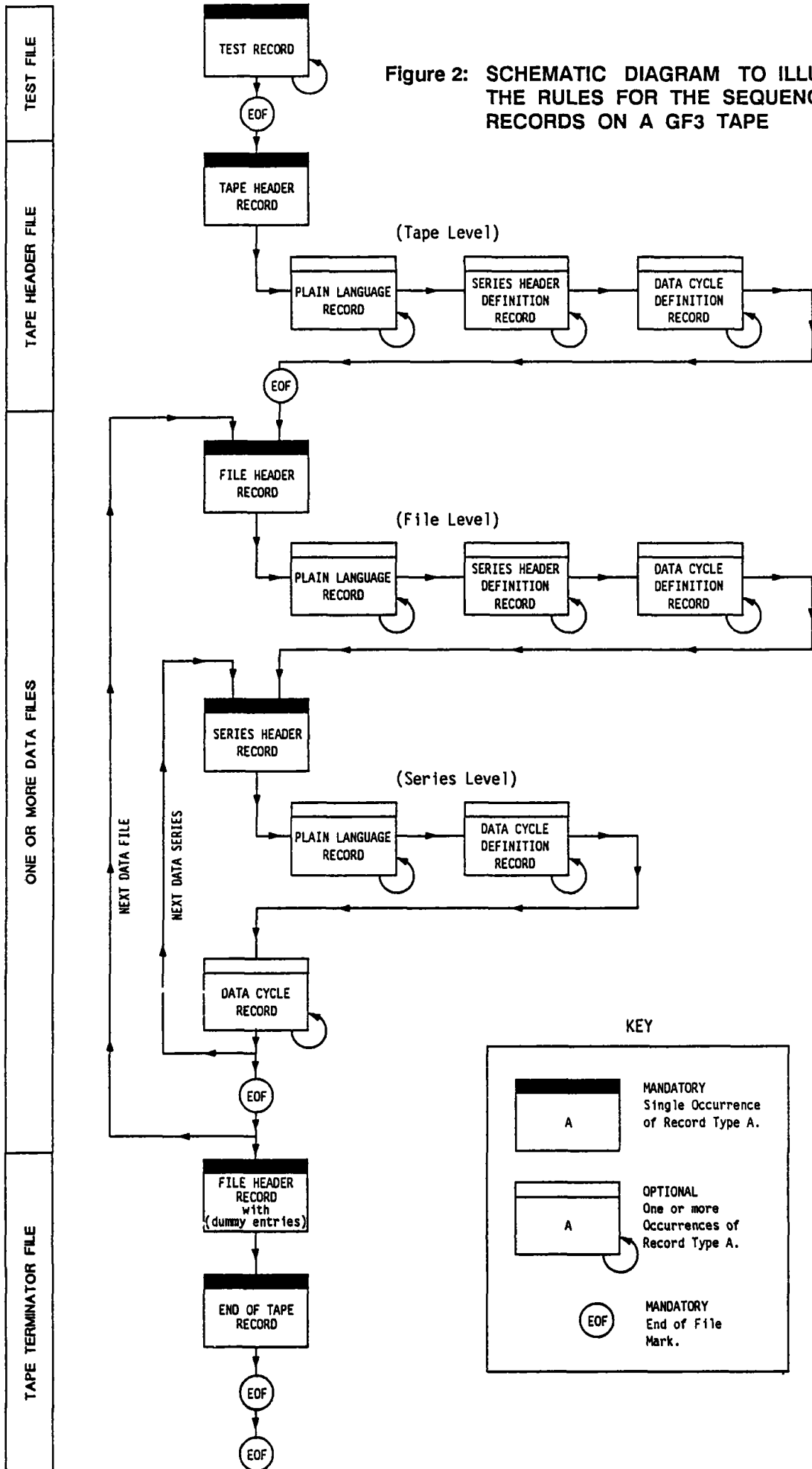

Figure 2: SCHEMATIC DIAGRAM TO ILLUSTRATE THE RULES FOR THE SEQUENCING OF RECORDS ON A GF3 TAPE

3.1.3 Plain language records, if present, will always appear immediately following the relevant tape, file or series header record.

3.1.4 At a given level any definition records are inserted after the plain language records if present - if plain language records are not present then the definition records are inserted directly after the relevant header record. At each level, series header definition records (i.e. records defining the format and contents of the 'user-defined area' of a series header record), if present, will always precede any data cycle definition records (i.e. records defining the 'user-defined area' of data cycle records).

3.1.5 Each data file will always contain at least one data series.

3.1.6 Each data series will always include data cycle records, unless all the data series in a data file are very short and their data can be contained within the 'user-defined area' of the series header record.

3.1.7 If data cycle records appear in the data set then corresponding data cycle definition records must also be present. Similarly, if data are included in the 'user-defined area' of any series header record, then corresponding series header definition records are required. If either of these two types of 'user-defined area' is not used, then the corresponding definition record is not required.

3.2 RULES OF PRECEDENCE FOR DEFINITION RECORDS

It will be noted that definition records may appear at more than one level in a given GF3 data set. The following rules of precedence apply:

3.2.1 Data cycle definition record(s), if present at series level, apply only to the data cycle records in that specific series.

3.2.2 Data cycle definition record(s), if present at file level, apply to the data cycle records of all series in that specific data file, except only for those series in the file that already have a data cycle definition record(s) at series level.

3.2.3 Series header definition record(s), if present at file level, apply only to the series header records in that specific file.

3.2.4 Definition records, if present at tape level, are generally applicable to the tape as a whole, but only become operative if corresponding records do not appear at file or series level.

3.2.5 Note that the presence of definition records in one file (or series) at file (or series) level does not necessarily imply that all other files (or series) must also have their definition records at file (or series) level. For example, if all files on the tape except one have the same content and format, then the definition records may, if convenient, be inserted at the tape level - the remaining file of a different content and format would have its definition records inserted at file or series level.

3.3 RECORD SEQUENCING WITHIN INDIVIDUAL FILES

The rules laid out in sections 3.1 and 3.2 are summarised below in terms of the organisation of records within individual files.

3.3.1 The Test File contains only one type of record - the test record. This record is repeated as many times as are required to ensure the file occupies about two metres of tape.

3.3.2 The Tape Header File will always start with a tape header record and may be followed by plain language records, series header definition records and data cycle definition records, in that order. The minimum requirement for a tape header file is a single tape header record. The remaining records are optional and are only included if they are generally applicable to the tape as a whole - they may appear in any number and combination, providing they are in the correct order. For exchange purposes it is normal to include plain language records over-viewing the contents of the tape and describing any special code tables or parameter codes used. If the tape contains a homogeneous set of data of the same type and format, then definition records will normally appear in the tape header file rather than at the file or series level.

3.3.3 Each Data File will always start with a file header record which may then be followed by 'file level' plain language records, series header definition records and data cycle definition records, in that order. These 'file level' records are optional and may appear in any number and combination providing they are in the correct order - they are only included if they are generally applicable to the file as a whole. There then follows at least one, but maybe more, data series.

Each data series will always start with a series header record which may then be followed by 'series level' plain language records and data cycle definition records - these 'series level' records are only included if series specific documentation is available, or if the formatting and content of the data cycle records in the series differ from those of other series within the file. Data for the series will then normally follow in a series of data cycle records. However, if all data series in the file are very short, the data may, in fact, be fully contained within the 'user-defined area' of the series header record (with occasional series header continuation records). The minimum requirement for a data series is simply a single series header record with data in its 'user-defined area'.

Each data file is terminated by a single EOF mark. Note that in GF3 each data file is completely independent from other data files within the data set. Indeed, providing there is no dependence on 'tape level' plain language or definition records, each data file is a completely self contained entity.

3.3.4 The Tape Terminator File will always contain a single file header record (with dummy entries) followed by a single end of tape record - it contains no other records.

SECTION 4

THE CONTENT AND FORMAT OF GF3 RECORDS

This section provides a description of those GF3 records and record areas that are of a fixed predefined format. Information on the formatting of the 'user-defined' areas of GF3 records (i.e. the last 1520 bytes of the series header record and the last 1900 bytes of the data cycle record), and on the content, format and use of GF3 definition records, is given in Section 5.

4.1 GENERAL RULES

Although each GF3 record type has its own distinctive content and format, certain general rules apply. These rules do not apply to the test record which is a special case.

4.1.1 Each GF3 logical record is of a fixed length of 1920 bytes and all fields are restricted to the use of the GF3 Common Character Set, as given in GF3 Code Table 2 (see Annex II).

4.1.2 The first byte of each GF3 record contains the record identifier appropriate to the record type thus:

0 : plain language record	5 : file header record
1 : tape header record	6 : series header record
3 : series header definition record	7 : data cycle record
4 : data cycle definition record	8 : end of tape record

4.1.3 The second byte of each GF3 record contains the record identifier of the following record. Note that EOF marks are not classed as records. With the exception of the tape terminator file, the second byte of the last record of each GF3 file will therefore always be set to '5' so as to reference the file header record of the following file. The second byte of the end of tape record will normally be set to the dummy value '9' unless the data is continued on another tape, in which case it is set to '1' to reference the tape header record of the following tape.

4.1.4 With the exception of the data cycle record, the fixed format areas of all GF3 records are designed as contiguous groups of 80 byte units - each unit being referred to as a line image.

The first byte in each line image contains the record identifier (as in 4.1.2), and the last three bytes (78 to 80) the sequence number of the line image, starting at '001' for the first 80 bytes, '002' for the second and so on through to '024' for the last line image in the record (or '005' in the case of the series header record where only the first 400 bytes are of a fixed format). Where the record contents are continued on a succeeding record of the same type, the sequencing is carried over e.g. set to '025' for the first 80 bytes of the following record and so on - this applies only to plain language or definition records.

The line image concept is used to provide a uniform and convenient line length within records for listings and video terminal displays, and to impose a strict pattern within GF3 records that can be easily checked for data corruption or formatting errors.

4.1.5 The content and format of each GF3 record type is specified on the following pages in terms of its constituent fields - each field being described under the headings:

Line no. : sequence no. within the record of the line image containing the field

Line byte no. : position occupied by the field within the line image, expressed in bytes (characters) relative to the beginning of the line image

Record byte no. : position occupied by the field within the record, expressed in bytes (characters) relative to the beginning of the record

Description of field : the field description is given in three parts -

- * a leading '#' if the field is mandatory
- * the Fortran format specification (see 5.2.3) for reading/writing the field
- * a description of the contents of the field

The specification of each record type is accompanied by a layout sheet to illustrate the content and layout of the record.

4.1.6 Fields marked as mandatory must contain a valid entry as described in the field description - these fields are identified on the layout sheet either by prefilled entries or by a solid bar placed over the space allocated for the field. Note that where information is not readily available or applicable for entry in a mandatory field, a null entry option is usually available e.g. 9's fill.

Non-mandatory fields are filled only if it is appropriate to do so and the relevant data/information is available - if entries for such fields are not available the field will normally be filled with blanks.

Many of the GF3 records include a number of unassigned fields - these are reserved for future use and should be filled with blanks.

4.1.7 With the exception of two fields in the definition record, all assigned fields in the fixed format parts of GF3 records are stored either as right justified integers ('I' format) or as alphanumeric character strings ('A' format). Those stored in alphanumeric form are identified on the layout sheets by a letter 'A' placed in the right hand corner above the field name.

4.2 TEST RECORD

The test record is used only in the test file at the beginning of a GF3 tape and comprises 1920 bytes, each set to the character 'A'.

4.3 PLAIN LANGUAGE RECORD

Plain language records are used for descriptive text to qualify the stored data and the liberal use of these records is strongly recommended to ensure that the data are fully documented. Plain language records may appear in any number at any of three levels:-

- i) at tape level (following the tape header record) if they apply to the tape as a whole
- ii) at file level (following the file header record) if they apply to the file as a whole
- iii) at series level (following the series header record) if they apply only to a specific series

Each plain language record contains 24 line images of 80 bytes each - the first byte of each line image contains the record identifier (i.e. '0') and the last three bytes (78 to 80) the line sequence number. The remaining space (76 bytes) in each line image is for free format text, except for the first line image in each record which has its second byte reserved for the 'next record type indicator' and only has space therefore for 75 bytes of text. The free format text may be continued on succeeding plain language records as required. For ease of text preparation without the need to anticipate record boundaries (to accommodate the shorter line) it is recommended that the 2nd byte of the second and succeeding line images in each plain language record should be set as blank, and that text be prepared with a fixed maximum line length of 75 characters.

4.3.1 PLAIN LANGUAGE RECORD SPECIFICATION

LINE NO.	LINE BYTE NO.	RECORD BYTE NO.	DESCRIPTION OF FIELDS (# = mandatory field)
1	1	1	# (I1) Record identifier - set to '0' to indicate plain language record
	2	2	# (I1) Record identifier of next record
	3-77	3-77	(75A1) Plain language comments or description
	78-80	78-80	# (I3) Line sequence number - set to '001'
2-24		81-1920	Bytes 2 to 77 (76A1) on each line image may be used for plain language comments or description - on each line image, byte 1 contains '0' the record identifier, byte 2 is normally left blank and bytes 78-80 contain the line sequence number ('002' to 024')

Plain language comments or description may be continued on succeeding plain language records, if necessary, using line sequence numbers '025' to '048'; '049' to '072' etc - each record used in this way should be formatted as above. Any line images not completed should be filled with blanks except for bytes 1 and 78-80 which should always be set to the record identifier '0' and the line sequence number respectively. In the exceptional case where more than 999 lines of comment are required, the line number sequencing is reset to '000' for line '1000', '001' for line '1001' etc.

4.4 TAPE HEADER RECORD

The tape header record contains administrative information about the tape and its source, and appears once only on the tape at the beginning of the tape header file. It is of a fixed format and contains 24 line images of 80 bytes each. The first two line images contain information on the creation of the tape such as the tape identifier, date and time of creation, the institution responsible for its creation, and the type of computer used, together with tape sequencing information. The third line image contains the standard GF3 Common Character Set as written by the particular computer writing the tape. The remaining line images are used for plain language comments written in free format text and which apply to the contents of the tape as a whole. These comments may be continued on succeeding plain language records as required.

4.4.1 TAPE HEADER RECORD SPECIFICATION

LINE NO.	LINE BYTE NO.	RECORD BYTE NO.	DESCRIPTION OF FIELDS (# = mandatory field)
1	1	1	# (I1) Record identifier - set to '1' to indicate tape header record
	2	2	# (I1) Record identifier of next record
	3-6	3-6	(4X) Unassigned - blank filled
	7-8	7-8	# (2A1) IOC Country Code for the country of the institution or data centre that wrote (originated) this tape - coded as in GF3 Code Table 1 (see Annex I)
	9	9	(I1) Flag to indicate the code table in use in the following field - for the present set to '9' if a national institution code table is in use, otherwise blank filled
	10-12	10-12	(3A1) Institution code (if available) of the institution or data centre that wrote (originated) this tape - coded according to code table indicated in preceding field
	13-24	13-24	# (12A1) Tape name or number - unique to institution that wrote (originated) this tape
	25-29	25-29	(5X) Unassigned - blank filled
	30-41	30-41	(12A1) Name or number of preceding tape (if data is continued from another tape) - as entered in bytes 13-24 of the tape header record of the preceding tape. Blank filled if not a continuation tape
	42-59	42-59	# (18A1) Country - plain language - name of country of the institution that wrote (originated) this tape
	60-77	60-77	# (18A1) Institution - plain language - name of the institution or data centre that wrote (originated) this tape
	78-80	78-80	# (I3) Line sequence number - set to '001'

LINE NO.	LINE BYTE NO.	RECORD BYTE NO.	DESCRIPTION OF FIELDS (# = mandatory field)
2	1	81	# (I1) Record identifier - set to '1'
	2-7	82-87	# (3I2) Date (YYMMDD) that this tape was written by above institution or data centre
	8-13	88-93	# (3I2) Date (YYMMDD) that first version of the data on this tape was written by above institution (same as bytes 82-87 unless previous versions were in error or lost, etc)
	14-19	94-99	(3I2) Date (YYMMDD) that this tape was received at receiving data centre or institute (must be set to 9s when tape is written - can only be 'filled-in' if receiving institution copies the tape)
	20-25	100-105	(3I2) Date (YYMMDD) that first version of this tape was received (must be set to 9s when tape is written - can only be 'filled-in' if receiving institution copies the tape) (same as bytes 94-99 unless data updated) <u>Note:</u> for the above four fields: YY = last two digits of year MM = month DD = day of month
	26-37	106-117	(12A1) Type of computer used to write this tape (plain language) - Manufacturer and Model
	38-42	118-122	# (5A1) Acronym of format version used - set to 'GF3.2'
	43-77	123-157	(35X) Unassigned - blank filled
	78-80	158-160	# (I3) Line sequence number - set to '002'
3	1	161	# (I1) Record identifier - set to '1'
	2-53	162-213	# (52A1) Translation table containing GF3 Common Character Set as listed in GF3 Code Table 2 (see Annex II)
	54-73	214-233	(20X) Unassigned - blank filled
	74-77	234-237	# (I4) Record size in bytes - set to '1920'
	78-80	238-240	# (I3) Line sequence number - set to '003'
4-24		241-1920	Bytes 2 to 77 (76A1) on each line image may be used for plain language comments or description - on each line image, byte 1 contains '1' the record identifier, and bytes 78-80 contain the line sequence number ('004' to '024') - as with plain language records it is recommended that byte 2 of each line image should be set as blank - see section 4.3

Plain language comments or description may be continued on succeeding plain language records, if necessary, using line sequence numbers '001' to '024'; '025' to '048' etc. In particular where the user has defined his own parameter codes or units (see GF3 Code Table 7 - Annex VII) a full definition of each such code or unit should be included in this plain language area.

4.5 FILE/SERIES HEADER RECORD

The file header record is used to define the beginning of a data file while the series header record defines the beginning of a data series. Whereas the information in the file header record pertains to a data file as a whole, that in the series header record relates only to a specific series.

The first 400 bytes of both the file header record and the series header record are formatted in an identical fashion, although minor variations exist in the usage of certain fields. The format of these 400 bytes is fixed and built up as five 80 byte line images, as described in section 4.5.1. The first line image identifies the original source (collector) of the data and also includes the name of the project under which the data were collected, and any identifiers assigned to the file/series by the data centre responsible for preparing the data for archiving. The second line image contains descriptive information and identifiers of the platform (e.g. ship or aircraft) from which the data were collected. Similar information is included on the third line image for those cases where a secondary platform supports the observation platform e.g. for a buoy system, the buoy may be considered as the primary platform and the ship to which the data is telemetered as the secondary platform. The fourth and fifth line images contain a range of fields for describing the location of the data in space and time - different fields are used depending on whether the data are collected at a fixed position and/or depth. Depth may be expressed relative to the sea surface or to the sea floor. Also included are a validation flag for the data, and any identifiers assigned to the file/series by the data originator.

The formatting and contents of the last 1520 bytes of the record varies depending on whether it is used as a file header record or a series header record. The last 1520 bytes of a file header record are formatted for the storage of plain language comments (see section 4.5.3). However, the last 1520 bytes of a series header record are 'user-defined' and contain data formatted according to the relevant series header definition record (see section 4.5.2). If no such definition record is present the bytes are all blank filled.

The sole function of the file header record at the beginning of the tape terminator file is to protect the file independence of the preceding data file. It contains minimal information but, nevertheless, must accord with the formatting specification of the file header record. Recommended pre-filled entries for this record are described in section 4.5.4.

4.5.1 FILE/SERIES HEADER RECORD SPECIFICATION (FIRST 400 BYTES)

LINE NO.	LINE BYTE NO.	RECORD BYTE NO.	DESCRIPTION OF FIELDS (# = mandatory field) (S# = field mandatory for series header record only)
1	1	1	# (I1) Record identifier - set to '5' to indicate file header record or to '6' to indicate series header record
	2	2	# (I1) Record identifier of next record
	3-11	3-11	(9A1) Name or acronym of project under which data was collected
	12-13	12-13	S# (2A1) IOC Country Code for the country of the institution collecting/originating the data in the file/series (i.e. the original source of data) - coded as in GF3 Code Table 1 (Annex I)
	14	14	(I1) Flag to indicate the code table in use in the following field - for the present set to '9' if a national institution code table is in use, otherwise blank filled

LINE NO.	LINE BYTE NO.	RECORD BYTE NO.	DESCRIPTION OF FIELDS (# = mandatory field) (S# = field mandatory for series header record only)
1	15-17	15-17	(3A1) Institution code (if available) of the institution collecting/originating the data in the file/series - coded according to code table indicated in preceding field
	18-35	18-35	S# (18A1) Plain language name of country of institution collecting/originating the data in the file/series
	36-53	36-53	S# (18A1) Plain language name of institution collecting/originating the data in the file/series
	54-59	54-59	# (3I2) Date (YYMMDD) this version of the file/series was created (YY=last two digits of year, MM=Month, DD=Day)
	60-65	60-65	(3I2) Time (HHMMSS) this version of the file/series was created (HH=Hours, MM=Minutes, SS=Seconds)
	66-77	66-77	(12A1) Processing number or identifier assigned to the file/series by archiving data centre
	78-80	78-80	# (I3) Line sequence number - set to '001'
2	1	81	# (I1) Record identifier - set to '5' or '6' as for byte 1 of line 1
	2-3	82-83	(I2) Platform type code (primary platform) - coded as in GF3 Code Table 3 (see Annex III)
	4-11	84-91	(8A1) Platform type in plain language (e.g. ship, buoy, aircraft, float, grid, etc)
	12	92	(A1) Flag to indicate the code system used in the following field - coded as in GF3 Code Table 4 (see Annex IV)
	13-21	93-101	(9A1) Specific platform code to identify the primary platform e.g. ship code, aircraft call sign, mooring or buoy identifier etc - coded according to system indicated in preceding field
	22-43	102-123	(22A1) Plain language name of primary platform e.g. ship name
	44-53	124-133	(10A1) Reference number/identifier assigned by the institution originating the data to the cruise/flight/deployment... of the platform, during which the data was collected
	54-65	134-145	(I4,4I2) Date/time (YYYYMMDDHHMM) in GMT at start of cruise/flight/deployment...
	66-77	146-157	(I4,4I2) Date/time (YYYYMMDDHHMM) in GMT at end of cruise/flight/deployment... <u>Note:</u> in the above two fields YYYY=year, MM=month, DD=day, HH=hours, MM=minutes. Entered to the appropriate precision leaving remaining digits blank
	78-80	158-160	# (I3) Line sequence number - set to '002'

GF3 FILE / SERIES HEADER RECORD (1st 400 chars.)

1 2 3 4 5 6 7 8 9 10 11 12 13 14 15 16 17 18 19 20 21 22 23 24 25 26 27 28 29 30 31 32 33 34 35 36 37 38 39 40 41 42 43 44 45 46 47 48 49 50 51 52 53 54 55 56 57 58 59 60 61 62 63 64 65 66 67 68 69 70 71 72 73 74 75 76 77 78 79 80

ORIGINAL SOURCE OF DATA

RECORD ID	PROJECT NAME	COUNTRY CODE	INSTITUTION CODE	NAME OF COUNTRY - ORIGINAL SOURCE OF DATA (Plain Language)	NAME OF INSTITUTION - ORIGINAL SOURCE OF DATA (Plain Language)	DATE FILE/SERIES WAS CREATED	TIME FILE/SERIES WAS CREATED	PROCESSING NUMBER ASSIGNED TO FILE/SERIES BY DATA CENTRE	LINE SEQUENCE NUMBER
NEXT RECORD	A	A	A	A	A	Y Y M M D D	H H M M S S	A	
									001

PRIMARY PLATFORM

RECORD ID	PLATFORM TYPE	SPECIFIC PLATFORM CODE	PLATFORM NAME	ORIGINATOR'S CRUISE/FLIGHT/DEPLOYMENT IDENTIFIER	DURATION OF CRUISE/FLIGHT/DEPLOYMENT	LINE SEQUENCE NUMBER
CODE	A	A	A	A	START DATE/TIME END DATE/TIME	
NAME (Plain Language)	CODE FLAG	CODE	(Plain Language)	CRUISE/FLIGHT/DEPLOYMENT IDENTIFIER	C C Y Y M M D D H H M M C C Y Y M M D D H H M M	
						002

SECONDARY PLATFORM

						003
--	--	--	--	--	--	-----

SPACE/TIME COORDINATES

RECORD ID	START DATE/TIME	END DATE/TIME	POSITION (IF FIXED)	POSITIONAL ERROR/RANGE	(-LAND ELEVATION)	OBSERVATION DEPTH	OBSERVATION DEPTH	MINIMUM OBSERVATION	MAXIMUM OBSERVATION	LINE SEQUENCE NUMBER
	C C Y Y M M D D H H M M S S	C C Y Y M M D D H H M M S S	LATITUDE LONGITUDE	N W	SEA FLOOR DEPTH	RELATIVE TO SEA LEVEL	RELATIVE TO SEA FLOOR	DEPTH BELOW SEA LEVEL	DEPTH BELOW SEA LEVEL	
			D D M M H H D D D M M H H	N W	M M M M M T	M M M M M T	M M M M M T	M M M M M T	M M M M M T	
										004

● HEIGHTS ABOVE SEA LEVEL EXPRESSED AS NEGATIVE VALUES

POSITION LIMITS: IDENTIFIERS & COUNTS

RECORD ID	START/SOUTHERN LATITUDE	START/WESTERN LONGITUDE	END/NORTHERN LATITUDE	END/EASTERN LONGITUDE	OCEAN/SEA AREA CODE	BLANKS	VALIDATION	IDENTIFIER ASSIGNED TO FILE/SERIES BY DATA ORIGINATOR	NUMBER OF SERIES IN FILE	BLANKS	NUMBER OF DATA CYCLES IN THIS RECORD	BLANKS	CONTINUATION	LINE SEQUENCE NUMBER
USAGE FLAG	A	A	A	A	A	A	A	A						
D	D D M M H H	D D D M M H H	D D M M H H	D D D M M H H										
														005

1 2 3 4 5 6 7 8 9 10 11 12 13 14 15 16 17 18 19 20 21 22 23 24 25 26 27 28 29 30 31 32 33 34 35 36 37 38 39 40 41 42 43 44 45 46 47 48 49 50 51 52 53 54 55 56 57 58 59 60 61 62 63 64 65 66 67 68 69 70 71 72 73 74 75 76 77 78 79 80

LINE NO.	LINE BYTE NO.	RECORD BYTE NO.	DESCRIPTION OF FIELDS (# = mandatory field)
3	1	161	# (I1) Record identifier - set to '5' or '6' as for byte 1 of line 1
	2-77	162-237	Secondary platform information in same format as record bytes 82-157. This line image is used for those cases where a secondary platform supports a primary platform e.g. for a buoy system the buoy may be considered as the primary platform and the ship to which the data is telemetered as the secondary platform. If no secondary platform is usefully identified then the fields are filled with blanks
	78-80	238-240	# (I3) Line sequence number - set to '003'
4	1	241	# (I1) Record identifier - set to '5' or '6' as for byte 1 of line 1
	2-15	242-255	# (I4,5I2) Date/time (YYYYMMDDHHMMSS) in GMT of the earliest observation in the file/series - filled with 9's if not applicable
	16-29	256-269	(I4,5I2) Date/time (YYYYMMDDHHMMSS) in GMT of the latest observation in the file/series <u>Note:</u> in the above two fields YYYY=year, MM=month, DD=day, HH=hours, MM=minutes and SS=seconds. Entered to the appropriate precision leaving remaining digits blank
	30-36	270-276	# (3I2,A1) Fixed latitude (DDMMHHQ) - entered only if all observations in the file/series are collected at the same geographic position - otherwise filled with 9's
	37-44	277-284	# (I3,2I2,A1) Fixed longitude (DDDMMHHQ) - entered only if all observations in the file/series are collected at the same geographic position - otherwise filled with 9's <u>Note:</u> in the above two fields DD(DDD)=degrees, MM=minutes, HH=hundredths of a minute and Q is set to N(North) or S(South) for latitude; or E(East) or W(West) for longitude
	45-47	285-287	(I3) Positional uncertainty or range of observations in the file/series about the position entered in bytes 270-284, expressed in <u>tenths of a nautical mile</u>
	48-53	288-293	(I6) Sea floor depth (or land elevation), <u>in tenths of a metre</u> below sea level, at the position entered in bytes 270-284. (For land based measurements, this field may be used for the elevation of the ground above sea level, providing it is expressed as a negative value). Blank filled or set to zero if not applicable, or not known
	54-59	294-299	# (I6) Depth of observations below sea level <u>in tenths of a metre</u> (height above sea level is expressed as a negative value) - entered only if all observations in the file/series are collected at the same depth relative to sea level - otherwise filled with 9's

LINE NO.	LINE BYTE NO.	RECORD BYTE NO.	DESCRIPTION OF FIELDS (# = mandatory field)
4	60-65	300-305	# (I6) Depth of observations below sea floor <u>in tenths of a metre</u> (height above sea floor is expressed as a negative value) - entered only if all observations in the file/series are collected at the same depth relative to the sea floor - otherwise filled with 9's. An entry in this field should be accompanied by an entry in bytes 288-293 wherever possible
	66-71	306-311	# (I6) Minimum observation depth for data in the file/series <u>in tenths of a metre</u> below sea level (height above sea level expressed as a negative value) - should be filled with 9's if not known or an entry has been made in bytes 294-299 or 300-305
	72-77	312-317	# (I6) Maximum observation depth for data in the file/series <u>in tenths of a metre</u> below sea level (height above sea level expressed as negative value) - should be filled with 9's if not known or an entry has been made in bytes 294-299 or 300-305
	78-80	318-320	# (I3) Line sequence number - set to '004'
5	1	321	# (I1) Record identifier - set to '5' or '6' as for byte 1 of line 1
	2	322	# (I1) Flag to define the usage of fields in bytes 323-352 - set as follows: '1' fields define position at the start and the end of the file/series '2' fields define the limits within which all data in the file/series were collected '9' fields not used - in which case they are 9's filled Note that, if all data in the file/series were collected at the same position, the position is entered in bytes 270-284, and bytes 322-352 are set to 9's
	3-9	323-329	# (3I2,A1) Start/southern latitude (DDMMHHQ)
	10-17	330-337	# (I3,2I2,A1) Start/western longitude (DDMMHHQ)
	18-24	338-344	# (3I2,A1) End/northern latitude (DDMMHHQ)
	25-32	345-352	# (I3,2I2,A1) End/eastern longitude (DDMMHHQ) <u>Note:</u> for the above four fields DD(DDD)=degrees, MM=minutes, HH=hundredths of a minute and Q is set to N(North) or S(South) for latitude; or E(East) or W(West) for longitude
	33-35	353-355	(3A1) Code for ocean/sea area in which all or most of the data in the file/series were collected - coded as in GF3 Code Table 5 (see Annex V)
	36-37	356-357	(2X) Unassigned - blank filled
	38	358	(A1) Validation flag for data in this file/series - coded as in GF3 Code Table 6 (see Annex VI)
	39-50	359-370	(12A1) Identifier assigned to this file/series by the institute collecting (originating) the data

LINE NO.	LINE BYTE NO.	RECORD BYTE NO.	DESCRIPTION OF FIELDS (# = mandatory field)
5	51-56	371-376	# (I6) Number of series within this file - 9's filled if unspecified/unknown or if this record is a series header record
	57-62	377-382	(6X) Unassigned - blank filled
	63-66	383-386	# (I4) Number of data cycles actually stored within the last 1520 bytes of this record (as defined by the relevant series header definition record - see section 4.5.2) - set to '0' if there are none or if the record is a file header record. The count does not include any header parameters that may be present
	67-76	387-396	(10X) Unassigned - blank filled
	77	397	# (I1) Continuation flag - set to '1' (one) if the series header data cycles cannot be contained within the last 1520 characters of this record and are continued on the next series header record. Set to '0' (zero) if not applicable (see section 4.5.2)
	78-80	398-400	# (I3) Line sequence number - set to '005'

4.5.2 SERIES HEADER RECORD SPECIFICATION (LAST 1520 BYTES)

The last 1520 bytes of the series header record are 'user-defined' and contain data formatted according to the relevant series header definition record (see Section 5). If no such definition record is present the bytes are all blank filled.

If 'header parameters' are defined in the series header definition record they are each entered once only at the beginning of this 'user-defined area' and before any data cycles. Any data cycles defined in the series header definition record are then entered in the sequence (data cycle 1),(data cycle 2)...(data cycle N) where N is specified in bytes 383-386 (i.e. bytes 63-66 of line image '005') of this series header record (see section 4.5.1). The remaining space following (data cycle N) is blank filled to the end of the record. Any header or data cycle parameters not used within the 'user-defined area' are filled with an appropriate 'dummy value' (see section 5.2.5).

If all the data cycles cannot be contained within the 'user-defined area' they may be continued on the following series header record(s) in which case:-

- i) the 'continuation flag' in byte 397 (i.e. byte 77 of line image '005') of the series header record is set to '1' (see section 4.5.1)
- ii) the first 400 bytes of the series header record are repeated at the beginning of the following series header record except for record bytes 2 (next record ID), 383-386 (no of data cycles in record) and 397 (continuation flag) which are set to their appropriate values
- iii) the values of any 'header parameters' defined in the 'user-defined area' are then repeated in the following series header record, before the data cycles are then continued
- iv) note that individual data cycles may not overlap series header records i.e. each 'user defined area' must contain an integral number of complete data cycles

4.6 DATA CYCLE RECORD

Data cycle records are utilised for actual data only. Except for the first 20 characters, which contain information for accounting purposes in reading data cycles from the tape, the remaining 1900 bytes are 'user-defined' according to the relevant data cycle definition record. Data cycle records are not used without an appropriate data cycle definition record.

Within a given data series all data cycle records are of the same format although the amount of unused, but blank filled, space at the end of each record may vary depending on the number of data cycles present.

4.6.1 DATA CYCLE RECORD SPECIFICATION

RECORD BYTE NO.	DESCRIPTION OF FIELDS (# = mandatory field)
1	# (I1) Record identifier - set to '7' to indicate data cycle record
2	# (I1) Record identifier of next record
3-6	# (I4) Number of data cycles in the last 1900 bytes of this record
7-15	# (I9) Total number of data cycles preceding this record - set to zero for the first data cycle record in the series
16-20	# (I5) Data Cycle Record count - sequence number of this record within the series - starting at 1 for the first Data Cycle Record in the series

The remaining 1900 bytes of the record are user-defined and contain data formatted according to the relevant data cycle definition record (see Section 5). Data cycles are entered in the sequence (data cycle 1),(data cycle 2),...(data cycle N) where N (specified in bytes 3-6 above) is not greater than the largest number of complete data cycles that can be stored in 1900 bytes. The remaining space following data cycle N is blank filled. The data cycles are continued on as many data cycle records as are required to complete the series - note that individual data cycles should not overlap records i.e. each record must contain an integral number of complete data cycles.

If 'header parameters' are defined in the data cycle definition record they are entered following byte 20 and before the data cycles - they occur once only in each record. The accounting fields (i.e. bytes 1 to 20) are not considered as 'header parameters' as referenced by the data cycle definition record.

Any header or data cycle parameters not used within the 'user-defined area' are filled with an appropriate 'dummy value' (see section 5.2.5).

4.7 END OF TAPE RECORD

The end of tape record appears once only on a tape and is the last record on the tape. The main purpose of this record is to terminate the tape and to indicate whether the data is continued on a further tape. Except for record type identification and sequence numbers it contains only one field viz. the name or number of the tape, if any, on which the data is continued. The rest of the record is left free for the inclusion of plain language comments, if required.

4.7.1 END OF TAPE RECORD SPECIFICATION

LINE NO.	LINE BYTE NO.	RECORD BYTE NO.	DESCRIPTION OF FIELDS (# = mandatory field)
1	1	1	# (I1) Record identifier - set to '8' to indicate end of tape record
	2	2	# (I1) Record identifier of next record - if the data set is continued on another tape this byte is set to '1' to indicate a tape header record - if the data set is not continued it is set to '9'
	3-12	3-12	# (10A1) These bytes are all set to '9'
	13-24	13-24	# (12A1) Identifying name or number of tape on which the data set is continued - as entered in bytes 13-24 of the tape header record of the continuation tape. These bytes are all set to '9' if data set is not continued
	25-77	25-77	# (53A1) These bytes are all set to '9'
	78-80	78-80	# (I3) Line sequence number - set to '001'
2-24		81-1920	Bytes 3 to 77 (75A1) on each line image may be used for plain language comments or description as appropriate. On each line image, byte 1 contains '8' the record identifier, byte 2 is normally set as blank and bytes 78-80 contain the line sequence number ('002' to '024')

SECTION 5

THE DEFINITION RECORD AND THE 'USER-DEFINED AREAS' OF GF3 RECORDS

This Section describes the format and contents of the GF3 definition record and explains how it may be used to define the format and contents of the 'user-defined areas' of other GF3 records.

5.1 THE USE OF DEFINITION RECORDS

The last 1520 bytes of the series header record and the last 1900 bytes of the data cycle record are the main areas for the storage of actual data. The content and format of these areas are defined by the user through definition records stored with the data. There are two types of definition record:

- i) series header definition record for defining the 'user-defined area', i.e. last 1520 bytes, of the series header record
- ii) data cycle definition record for defining the 'user-defined area', i.e. last 1900 bytes of the data cycle record

These two types of definition record are used independently of each other, although they have the same basic format and are used in a similar fashion.

5.1.1 GENERAL PRINCIPLES

Each data field defined in a 'user-defined area' is called a parameter and each definition record allows for the definition of up to 21 such parameters. If the 'user-defined area' contains more than 21 parameters the definition is continued on a succeeding definition record(s) of the same type.

Two types of parameter may be stored in the 'user-defined area' of a record:

- i) header parameters i.e. parameters that occur once only in the 'user-defined area' of each record covered by the definition record(s)
- ii) data cycle parameters i.e. parameters that are repeated as many times as there are data cycles within the 'user-defined area' of each record covered by the definition record(s)

A 'user-defined area' may contain header parameters and/or data cycle parameters.

In the 'user-defined area' of a record, header parameters, if present, are all stored before any data cycle parameters. The parameters are defined in the definition record in the same order as they appear in the 'user-defined area' - header parameters, if any; are first defined in order - data cycle parameters, if present, are then defined in the same order as they appear in an individual data cycle. Any data cycles present in a 'user-defined area' must all be of the same format and content. If the value of any defined parameter is missing it is filled with a user-defined 'dummy value'.

Within the definition record each parameter definition includes a parameter code; parameter name; units and scaling factors; the field length and Fortran format type in which the parameter value is stored in the 'user-defined area'; a 'dummy value code' for identifying the null or dummy value; a discriminator between repeated definitions of the same parameter; and a secondary parameter code. The secondary parameter is used for defining parameter attributes.

Each parameter stored in a 'user-defined area' must accord with one of the Fortran format types A (alphanumeric string), I (right justified integer) or F (floating point or real). Format types E or D are not allowed, although the parameter may be split into its mantissa and exponent parts and stored as two separate parameters (see parameter EEEE7XXN in GF3 Code Table 7 in Annex VII).

The definition record also includes the Fortran format statement necessary to read/write the complete contents of the 'user-defined area'. The format statement defines the positioning of the parameter fields within the 'user-defined area' including the repeat specifications for the storage of any data cycles present. Note that individual data cycles are not allowed to overlap records i.e. each 'user-defined area' must contain either zero or an integral number of data cycles.

5.1.2 DATA CYCLE DEFINITION RECORDS

Within any given data series all data cycle records are of the same format and content as defined by the relevant data cycle definition record(s).

As discussed in Section 3 (see Figure 2 on page 8) a data cycle definition record(s) may occur at more than one level on a given tape viz:

- i) tape level - at the end of the tape header file
- ii) file level - immediately preceding the first series header record in the relevant data file
- iii) series level - immediately preceding the first data cycle record in the relevant data series

The following rules of precedence apply:

- i) a data cycle definition record(s) at series level applies only to the data cycle records in that specific data series
- ii) a data cycle definition record(s) at file level applies to the data cycle records of all series in that specific data file only, except for those series in the file that already have a data cycle definition record(s) at series level
- iii) a data cycle definition record(s) at tape level is generally applicable to all data cycle records on the tape, but only becomes operative if another data cycle definition record(s) is not already operative at the relevant file or series level

Data cycle records are only meaningful if a relevant data cycle definition record is present.

5.1.3 SERIES HEADER DEFINITION RECORDS

Within any given data file the 'user-defined area' of all series header records in the file are of the same format and content as defined by the relevant series header definition record(s).

As discussed in Section 3 (see Figure 2 on page 8) a series header definition record(s) may occur at more than one level on a given tape viz:

- i) tape level - after the plain language records, if any, following the tape header record
- ii) file level - after the plain language records, if any, following the file header record in the relevant data file

The following rules of precedence apply:

- i) a series header definition record(s) at file level applies only to the series header records in that particular data file
- ii) a series header definition record(s) at tape level is generally applicable to all series header records on the tape, but only becomes operative if another series header definition record is not already operative at the relevant file level

The 'user-defined area' of the series header record is blank filled if a relevant series header definition record is not present.

5.2 FORMAT AND CONTENT OF DEFINITION RECORDS

Both the series header definition record and the data cycle definition record accord to the same format specification although they are used independently of each other. The two types of definition record are distinguished by the record identifier placed in the first byte of the record. The definition records are of a fixed format and contain 24 line images of 80 bytes each.

The first line image of a definition record contains counts of the number of header parameters and data cycle parameters included within the 'user-defined area' being defined and indicates whether integer, real, alphanumeric or mixed Fortran field types are present in the area. It also contains Part 2 of the Fortran format statement necessary to read/write the series header record or data cycle record containing the 'user-defined area' (as described in section 5.2.2). The second and third line images contain further portions of the Fortran format statement as necessary.

Each of the remaining 21 line images contains the definition of one of the parameters included in the 'user-defined area', specified in the order in which they appear in the area. If the 'user-defined area' contains more than 21 parameters the parameter definitions are continued on a succeeding definition record(s) of the same type.

5.2.1 SERIES HEADER / DATA CYCLE DEFINITION RECORD SPECIFICATION

LINE NO.	LINE BYTE NO.	RECORD BYTE NO.	DESCRIPTION OF FIELDS (# = mandatory field)
1	1	1	# (I1) Record identifier - set to '3' for series header definition record or to '4' for data cycle definition record
	2	2	# (I1) Record identifier of next record
	3-5	3-5	# (I3) Number of parameters in the header section of the 'user-defined area' defined by this record ('header parameters')
	6-8	6-8	# (I3) Number of parameters in each data cycle of the 'user-defined area' defined by this record ('data cycle parameters')
	9	9	# (A1) One character code summarising the Fortran format types associated with the parameters stored in the 'user-defined area' - set as follows:- 'I' - all are written as integer numbers 'F' - all are written as real numbers (i.e. floating point) 'A' - all are written as alphanumeric characters 'M' - mixture of real and integer numbers and alphanumeric characters 'P' - mixture of integer numbers and alphanumeric characters 'Q' - mixture of real numbers and alphanumeric characters 'S' - mixture of real and integer numbers
	10-17	10-17	(8X) Unassigned - blank filled
	18-77	18-77	# (60A1) Part 2 of the Fortran format statement required to read/write data from/to the 'user-defined area' - see section 5.2.2
	78-80	78-80	# (I3) Line sequence number - set to '001'
	2	1	81
2-17		82-97	(16X) Unassigned - blank filled
18-77		98-157	(60A1) Part 3 of the Fortran format statement (blank filled if not required) - see section 5.2.2
78-80		158-160	# (I3) Line sequence number - set to '002'
3	1	161	# (I1) Record identifier - set to '3' or '4' as for byte 1 of line 1
	2-17	162-177	(16X) Unassigned - blank filled
	18-77	178-237	(60A1) Part 4 of the Fortran format statement (blank filled if not required) - see section 5.2.2
	78-80	238-240	# (I3) Line sequence number - set to '003'

GF3 DEFINITION RECORD

1	2	3	4	5	6	7	8	9	10	11	12	13	14	15	16	17	18	19	20	21	22	23	24	25	26	27	28	29	30	31	32	33	34	35	36	37	38	39	40	41	42	43	44	45	46	47	48	49	50	51	52	53	54	55	56	57	58	59	60	61	62	63	64	65	66	67	68	69	70	71	72	73	74	75	76	77	78	79	80
RECORD ID	NEXT RECORD	NUMBER OF	HEADER	PARAMETERS	NUMBER OF	DATA CYCLE	PARAMETERS	PARAMETERS	FORMAT	A										FORTRAN FORMAT DESCRIPTION (PARTS 2, 3 & 4)										A										LINE	SEQUENCE	NUMBER																																					
										BLANKS																																																																					

RECORD ID	BLANK	PARAMETER CODE	PARAMETER DISCRIM.	NAME OF PARAMETER AND UNITS (Plain Language)	MODE	FIELD LENGTH	DUMMY VALUE CODE	SCALE 1 (*)	SCALE 2 (+)	ATTRIBUTE BLANK	SECONDARY PARAMETER CODE	SECONDARY PARAMETER DISCRIM.	LINE SEQUENCE NUMBER
1													
2													
3													
4													
5													
6													
7													
8													
9													
10													
11													
12													
13													
14													
15													
16													
17													
18													
19													
20													
21													
22													
23													
24													
25													
26													
27													
28													
29													
30													
31													
32													
33													
34													
35													
36													
37													
38													
39													
40													
41													
42													
43													
44													
45													
46													
47													
48													
49													
50													
51													
52													
53													
54													
55													
56													
57													
58													
59													
60													
61													
62													
63													
64													
65													
66													
67													
68													
69													
70													
71													
72													
73													
74													
75													
76													
77													
78													
79													
80													

LINE NO.	LINE BYTE NO.	RECORD BYTE NO.	DESCRIPTION OF FIELDS (# = mandatory field)
<u>PARAMETER 1</u>			
4	1	241	# (I1) Record identifier - set to '3' or '4' as for byte 1 of line 1
	2	242	(1X) Unassigned - blank filled
	3-10	243-250	# (8A1) Parameter Code - use standard parameter code as far as possible - coded as in GF3 Code Table 7 (see Annex VII)
	11-13	251-253	(I3) Parameter discriminator - number to uniquely identify the parameter in cases where other parameters in the 'user-defined area' have the same parameter code - see section 5.2.6
	14-40	254-280	# (27A1) Name of the parameter and its units - plain language. Note that the units are those of the retrieved value after the factors Scale 1 and Scale 2 have been applied (see section 5.2.4). The use of a standard parameter code in bytes 3-10 implies usage of standard units for that parameter as defined in GF3 Code Table 7
	41	281	# (A1) Mode - set to 'I', 'F' or 'A' depending on whether the parameter is stored in the 'user-defined area' as an integer number (I=integer), a real number (F=floating point) or as an alphanumeric string (A=alphanumeric) - see section 5.2.3
	42-45	282-285	# (I4) Number of character positions allocated for storing values of the parameter in the 'user-defined area'
	46-48	286-288	(I3) Dummy value code - see section 5.2.5
	49-56	289-296	# (F8.n) Scale 1 (*) - factor by which stored value of the parameter should be multiplied when retrieved from the 'user-defined area' - set to '1.0' if no conversion is required - see section 5.2.4
	57-64	297-304	# (F8.n) Scale 2 (+) - factor which should be <u>added</u> to the stored value of the parameter after the application of Scale 1 - set to '0.0' if no addition is required - see section 5.2.4
	65	305	(A1) Attribute Flag - set to 'A' if the parameter defined in this line image is used for the storage of the attribute of another parameter - otherwise set as blank - see section 5.2.7
	66	306	(1X) Unassigned - blank filled
	67-74	307-314	(8A1) Secondary Parameter Code - parameter code identifying the parameter whose attribute is being defined - coded as in GF3 Code Table 7 (see Annex VII). Only used if line byte 65 is set to 'A' - otherwise blank filled - see section 5.2.7
	75-77	315-317	(I3) Secondary Parameter Discriminator - contains the parameter discriminator, if any, of the parameter whose attribute is being defined. Only used if line byte 65 = 'A' - blank filled or set to zero if not used - see section 5.2.7
	78-80	318-320	# (I3) Line sequence number - set to '004'

PARAMETERS 2 TO 21

Parameter 2 and succeeding parameters (up to Parameter 21) in the 'user-defined area' are defined on line images '005' to '024' as required, in the same form as described above for Parameter 1.

PARAMETERS 22 TO 42; 43 TO 63; ETC

Further parameters are defined on succeeding Definition Records, as necessary, in the same format as above using line images '028' to '048' for PARAMETERS 22 to 42 on the 2nd record, line images '052' to '072' for PARAMETERS 43 to 63 on the 3rd record, etc.

The first 3 line images ('025' to '027' on the 2nd record; '049' to '051' on the 3rd record; etc) in each such succeeding definition record are blank filled except for the record identifier (line byte 1) which is set to '3' or '4' and the line sequence number (line bytes 78 to 80). In the first line image ('025' on the 2nd record; '049' on the 3rd record; etc) of each record byte 2 is set to the record identifier of the next record.

Note 1: Any unused line images at the end of a definition record are blank filled except for line byte 1 (record identifier) and line bytes 78 to 80 (line image sequence number). Such unused line images are only allowed after the last parameter has been defined

Note 2: The total number of definition records required is deduced from the sum of the number of 'header parameters' and the number of 'data cycle parameters' (bytes 3-8 of line image '001'). Parameters must be entered in the sequence in which they appear in the 'user-defined area' with the 'header parameters' appearing before the 'data cycle parameters'

Note 3: If any parameter has been defined using a non-standard Parameter Code and/or non-standard units then a detailed definition of the code and/or the units must be included in the plain language area of the tape header file or the file header record

5.2.2 FORTRAN FORMAT STATEMENT

5.2.2.1 There are two components of the Fortran format statement necessary to read/write a complete series header or data cycle record:

- i) the format of the fixed area of the record i.e. the first 400 bytes in the case of a series header record or the first 20 bytes in the case of a data cycle record. This component forms Part 1 of the Fortran format statement and can be deduced from the record specifications given in 4.5.1 and 4.6.1. It is not included in the definition record.
- ii) the format of the 'user-defined area' of the record i.e. the last 1520 bytes of a series header record or the last 1900 bytes of a data cycle record. This component forms Parts 2 to 4 of the Fortran format statement and is included in bytes 18 to 237 of the relevant definition record.

5.2.2.2 Fortran format of the fixed area of a series header record (Part 1)

Some flexibility is available in the way alphanumeric, and also integer, fields are read/written to or from the fixed area of the series header record and the following represents one possibility:

```
(2I1,11A1,I1,39A1,2I6,12A1,I3,  
2(I1,I2,8A1,A1,41A1,2(I8,I4),I3),  
I1,2(I8,I4,I2),I2,I4,A1,I3,I4,A1,I3,5I6,I3,  
2I1,2(I2,I4,A1,I3,I4,A1),3A1,2X,13A1,I6,6X,I4,10X,I1,I3,
```

Note - no closing bracket

5.2.2.3 Fortran format of the fixed area of the data cycle record (Part 1)

The Fortran format description of this section is far simpler and takes the form:

```
(2I1,I4,I9,I5,
```

Note again - no closing bracket

5.2.2.4 Fortran format of the 'user-defined area' of series header and data cycle records (Parts 2 to 4)

The Fortran format description of this section is given in bytes 18-237 of the relevant definition record. It must be entered on the definition record as though it was only needed for reading in the 'user-defined area', i.e. it should start with an opening bracket '(' and should completely disregard the fixed area of the record being defined. It should obey Fortran rules for repetition - all brackets must be paired. 3 x 60 = 180 bytes are allowed in the definition record for the format description (i.e. Parts 2 to 4) of the 'user-defined area'. 60 bytes will often be sufficient, but the extra space has been allotted to allow for more complex formats, e.g. if there is a large number of parameters. The format is terminated by the closing bracket ')' that pairs with the opening bracket '('. The remainder of the 180 bytes should be set to blank. If it is necessary to break the format into 60 byte parts, care should be taken not to leave significant blanks at the end of each part. Preferably, terminate each part at a comma ','.

The repeat specifications in the format statement must correspond with the number of parameters recorded once per record i.e. 'header parameters', and the number of parameters repeated each data cycle i.e. 'data cycle parameters'. In no case should individual data cycles be allowed to cross record boundaries, i.e. each record should contain an integral number of data cycles. In reading data cycles from the 'user-defined areas' of either series header or data cycle records the actual number of data cycles contained in that area is entered as a field in the 'fixed area' of the record (bytes 383 to 386 in the series header record or bytes 3 to 6 in the data cycle record).

The format statement should map precisely the space available in the 'user-defined area' (i.e. 1520 or 1900 bytes respectively). Any unassigned space at the end of the 'user-defined area' should be accounted for by an 'nX' field at the end of the Fortran format statement - where n = no. of unassigned bytes. Note that this field does not include unused data cycles - these are simply blank filled.

The format of each individual parameter, as specified in the Fortran format statement, must accord precisely with the mode and field length (bytes 41-45) defined for that parameter. Thus, for example, a parameter with a mode 'I' and length '3' should appear as I3 in the Fortran format statement - if it is preceded by a blank character the format should take the form 1X,I3 and not I4.

5.2.2.5 Fortran format of the complete record

The full Fortran format can be constructed by taking the format of the fixed area i.e. Part 1 and attaching to the end of it the format description for the 'user-defined area' (i.e. Parts 2 to 4) having first removed its opening '('.

5.2.2.6 Examples

- i) If in a data cycle record five parameters are recorded once per record (i.e. header parameters) with another seven in each data cycle (data cycle parameters) the format of the 'user-defined area' might perhaps be:-

```
(I4,I6,2I5,I4,36X,46(2I4,I3,4I6,5X))
      |           |           |
      5 header   |           7 data cycle
      parameters |           parameters
                  |
                  46 data cycles
```

Note that the repeat count and use of blanks ensures the statement maps precisely into the 1900 available bytes of the 'user-defined area'. In this example the format of the complete data cycle record would be:

```
(2I1,I4,I9,I5,I4,I6,2I5,I4,36X,46(2I4,I3,4I6,5X))
```

- ii) If however, the five header parameters are not repeated for each data cycle record but are constant for the series as a whole, they could be inserted as header parameters in the 'user-defined area' of the series header record whose format would take the form:

```
(I4,I6,2I5,I4,1496X)
```

The seven data cycle parameters could still remain in the data cycle record whose 'user-defined area' would now take the format:

```
(20X,47(2I4,I3,4I6,5X))
```

- iii) Alternatively, if the series is short all the data cycles might fit readily into the 'user-defined area' of the series header record together with the five header parameters - the 'user-defined area' of the series header record would then take the format:

```
(I4,I6,2I5,I4,16X,37(2I4,I3,4I6,5X))
```

Note that the repeat count is reduced to 37 as the 'user-defined area' of the series header record has space for only 1520 bytes.

Although the data cycle repeat count in the format statement included in the definition record is selected so as to fill the 'user-defined area', the actual number of data cycles present in the 'user-defined area' of a given record is specified in a count field in the fixed part of that record - this may, on occasions, be less than the repeat count in the format statement in which case the remainder of the 'user-defined area' is usually padded out with blanks.

5.2.3 FORTRAN FORMAT TYPES

Only Fortran format types A, I, F and X are used for fields in the fixed or 'user-defined areas' of GF3 records. These are defined as follows:

5.2.3.1 A : the 'A' format is used for data stored in the form of an alphanumeric character string. With Fortran 66 compilers, each alphanumeric field in a 'user-defined area' was normally represented in the Fortran format statement of the definition record in the form 'nA1'. However, with the introduction of character string fields in Fortran 77 it is now recommended to express such fields in the form 'An' - the GF3-Proc software supports both conventions. 'A' format fields are usually used for alphanumeric codes or for plain language text. However, it is recommended that before including plain language text fields in the 'user-defined areas' of GF3 records, the user should first investigate the possibility of incorporating that information in plain language records.

5.2.3.2 I : the 'I' format is used for arithmetic values which are whole decimal numbers i.e. integers - it may also be used for information expressed in a coded form where the code values are integers. It takes the form 'In' where n = field width in bytes. Spaces (blanks) are normally used instead of leading zeros to fill out the specified field. The decimal point is never included - negative integers are normally expressed with a minus sign before the leading non zero digit - positive integers are normally unsigned. Note that the sign is included within the byte width assigned to the format.

sample format	examples
I5	12345 or b1234 or bbbbl or -1234 or bb-12 (b=blank)
2I4	12341234 or bb12bb12 or b123b-12

Trailing blanks should not be used to fill a field because these are generally interpreted as zeros by computers. For example, a number written in 'I4' format as b12b would be read as 0120. 'I' format numbers should therefore be written right adjusted (written at the right-hand side of the field) with blanks or zeros for fill on the left. An all-blank field will generally be read as 0 (zero) or -0, depending on the computer used.

5.2.3.3 F : the 'F' format is used to express decimal values which are not inherently limited to integer numbers and can have integral and/or fractional values. It takes the form 'Fn.m' where n = field width and m = number of decimal places.

sample format	examples
F5.2	12.34 or b1.23 or bb.12 or -1.23 or b-.12
3F6.1	bb12.31234.5bb-1.2

Note that the decimal point counts as part of the field. As long as the decimal point is expressed, the format used to read the number or array may use any decimal-field size and still be read correctly. For example, if the format '3F6.2' were used to read the last example above, the numbers would still be 12.3, 1234.5 and -1.2. That is, the decimal point actually written on magnetic tape overrides the reading format specification.

However, if the decimal point does not appear in the written number, the specification in the read format will be followed. For example, if a field is written on tape as 1234 but is read back in 'F4.1' format, the read value will be 123.4. Care must be used in printing numbers read according to this example to avoid truncating the high-order digits.

It is recommended that 'F' format numbers should be written as 'F' format numbers with the decimal point in its proper position. They should also be right adjusted with zeros or blanks on the left. 'F' format numbers should then be read with the same format with which they were written or with the format 'Fn.0', where n is the field width.

5.2.3.4 X: the 'X' format is literally unspecified. Information written with this format will generally consist of blanks. Characters read under 'X' formats are disregarded. The main use of this format is to skip over characters when reading or to insert blank characters when writing.

5.2.3.5 It is recommended that, whenever possible, one should use the 'I' format rather than the 'F' format as the storage format in the 'user-defined areas' of GF3 records for parameters with numeric values. It should be noted that scaling factors are included in the definition of each parameter (definition record line bytes 49 to 64) and these may be used to convert non-integer values into an integer form (see section 5.2.4 below).

5.2.3.6 Whenever parameters with an extremely wide range of values are to be recorded, e.g. phyto-plankton data, pollution data, etc, one is tempted to use 'E' formats. However, because of the incompatibility of 'E' and 'D' formats on different computers the 'E' and 'D' formats are not allowed in GF3 - the problem may be overcome by recording the mantissa and the exponent of such parameters as separate parameters, each written in integer form. (See parameter EEEE7XXN in GF3 Code Table 7, i.e. Annex VII).

5.2.4 SCALING FACTORS

The definition of each parameter assigned to a 'user-defined area' includes a pair of scaling factors, Scale 1 (*) and Scale 2 (+). These appear in the definition record in bytes 49 to 64 of the line image containing the parameter's definition and may be used to:

- i) reduce the number of bytes needed to store the parameter e.g. in cases where the parameter value is inherently a large number but its variation is contained within its trailing digits
- ii) enable floating point numbers to be stored as integers, or
- iii) enable the stored parameter value to be converted into standard units upon retrieval

The scaling factors form the link between the true value of the parameter and the parameter value that is actually stored within the 'user-defined area'. Care must therefore be taken to ensure that the scaling factors are correctly specified in the definition record, and that they are applied correctly in the interchange of values between the user's program and the storage medium. In reading numeric data from the 'user-defined area' the following conversion should always be applied:-

$$\text{true value} = (\text{stored value} * \text{Scale 1}) + \text{Scale 2}$$

Similarly, when writing to the 'user-defined area' the inverse conversion must be applied viz:

$$\text{stored value} = \frac{\text{true value} - \text{Scale 2}}{\text{Scale 1}}$$

If, with numeric data ('I' or 'F' formats), the scaling factors are not used, then Scale 1 must be set to 1.0 and Scale 2 to 0.0 - to leave them blank may well result in erroneous values being retrieved. The only case when the scaling factors are left blank is when the parameter is stored in alphanumeric form, i.e. 'A' format.

It should be noted that the scaling factors are expressed in the definition record in floating point form (i.e. 'F' format) and that the conversions described will normally be carried out in Fortran in floating point arithmetic. If the conversion is to result in an integer value, care should be taken to ensure that the floating point value is rounded correctly.

Note that the units ascribed to a parameter in its definition refer, not to the stored value of the parameter, but to its true value as described above.

5.2.5 DUMMY VALUE CODE

The dummy value code is used to specify, in a coded form, the null value that should be stored in a 'user-defined area' to indicate that a particular parameter's value is absent; for example through an instrument malfunction or a missed reading. It is specified in the definition record in bytes 46 to 48 of the line image containing the parameter's definition. The first byte of the code specifies the sign of the absent data value; the second specifies the digit that is used; and the third specifies the number of times the digit is repeated. Examples of valid codes are:

dummy value code	null value
1	0
11	1
-11	-1
12	11
-12	-11
13	111
23	222
-33	-333
32	33
92	99
95	99999
-95	-99999

Note that dummy value codes of -9, -8.....-1, 0, 2, 3, 4.....9 are meaningless, as are codes with a units digit of 0 e.g. 10, 20, 30, etc, -90, -80, etc.

It is important that the width of the 'null value' is compatible with the width defined for the parameter field itself, e.g. there is no point assigning a 'dummy value code' of 95(99999), -94(-9999) for a parameter stored in 'I4' format, although 'dummy value codes' of 94(9999), -93(-999), etc would be acceptable.

For parameters stored in floating point form (i.e. 'F' format), the dummy value code is applied to the integer part of the stored value e.g. if the code is 93 then stored values such as 999.1, 999.2, etc would be treated as absent data values.

Should the parameter be stored as an alphanumeric field in 'A' format, dummy or null values are not required as the blank character already fulfils this function. For such parameters the dummy value code is left blank.

The entry of a blank dummy value code for a numeric parameter implies that a valid parameter value must always be present, i.e. it is never null. This normally applies only for parameters that represent the independent variables of a data series; for example, in a time series one would expect the parameter relating to the time of each data cycle always to contain a valid value.

Please note: The 'dummy value code' applies to the value of the parameter as it is actually stored in the 'user-defined area', i.e. before the factors Scale 1 and Scale 2 are applied to it. Thus for a parameter with Scale 1 = 5.0, Scale 2 = 3.0, 'dummy value code' = 93(999) the null value actually stored in the 'user-defined area' would be 999, although after application of the scaling factors it would become 4998.

5.2.6 THE PARAMETER DISCRIMINATOR

Most applications do not require the use of the parameter discriminator field (line image bytes 11 to 13) within the parameter line images of the series header/data cycle definition record. However, occasions do arise when the use of the parameter code is, by itself, insufficient to differentiate between parameters repeated within the same data cycle (or within the same set of header parameters) and a unique identifier is required - the parameter discriminator is used in conjunction with the parameter code to provide this identification. For example:

- i) A chain of 5 thermistors at 5 different depths recording within the same series may produce data cycles thus:

time, temperature, temperature, temperature, temperature, temperature.

In this case each of the five temperature parameters would have associated with it a unique parameter discriminator - e.g. a sequential number thus 1, 2, 3, 4 and 5 respectively. Each of the 5 parameters is now uniquely identified so that, for example, the depth of recording can be directly associated with each temperature value without ambiguity either within plain language records or through the parameter attribute mechanism (see next section).

- ii) A time series of counts on 5 different biological species may have data cycles thus:

time, depth, species count, species count, species count, species count, species count.

Each of the 5 parameters - species count - would have associated with it a unique parameter discriminator, e.g. 1, 2, 3, 4 and 5 respectively. The actual species type being counted in each of these parameters can then be associated with the parameter without ambiguity, either within plain language records or through the parameter attribute mechanism (again see next section).

5.2.7 PARAMETER ATTRIBUTES

A parameter attribute is a special type of parameter in that it provides additional data to qualify the value of another parameter stored in the 'user-defined area' of a series header or data cycle record. However, it is defined, stored and handled in exactly the same way as any other parameter except that its definition also includes a reference to the parameter that it qualifies. This reference is contained in what are called the Secondary Parameter fields which comprise the parameter code and parameter discriminator (if any) of the parameter that is being qualified. The concept is best illustrated by a simple example:

Consider the case of a drifting platform where all sensors except one are measuring at the sea surface but where the remaining sensor is allowed to drift at a variable depth and measures temperature. In addition to the parameters being measured at the surface the data cycles would also include the parameters 'sea temperature' and 'sensor depth' of the temperature sensor. These two parameters would be defined in the definition record in the normal manner with a parameter definition line image for 'temperature' and one for 'sensor depth'. The line image defining 'sensor depth' would also include the following entries:-

- byte 65 : Attribute - set to 'A' to indicate that 'sensor depth' is the attribute of another parameter
- bytes 67-74 : Secondary parameter code i.e. parameter code for 'sea temperature'
- bytes 75-77 : Secondary parameter discriminator - in this example it would be blank filled as only one 'sea temperature' parameter is being measured and it is uniquely identified solely by its parameter code

Consider now the case of the second example given in section 5.2.6 i.e. the time series of counts on 5 different biological species with data cycles containing the parameters:

time, depth, species count 1, species count 2,
species count 3, species count 4, species count 5,

and where each of the species count parameters is identified by the parameter code for 'species count' and a unique discriminator 1 to 5, but with no indication given as to which particular species is being counted. This may, of course, be described in the plain language records with comments such as 'species count 1 contains counts of species A', 'species count 2 contains counts of species B' etc where species A, B etc may be described in terms of their full latin name or a taxonomic code. An alternative approach is to treat the species identifier as an attribute of the parameter 'species count' and, for example, to include 5 additional header parameters in the 'user-defined area' of the series header record, each containing the taxonomic code appropriate to the species counted in one of the five 'species count' fields. Within the series header definition records the line images containing the definitions of these 5 parameters would include entries of the form:

	bytes 3-10 parameter code for	bytes 11-13 parameter discriminator	byte 65 attribute flag	bytes 67-74 parameter code for	bytes 75-77 parameter discriminator
i)	'species ID'	1	A	'species count'	1
ii)	'species ID'	2	A	'species count'	2
iii)	'species ID'	3	A	'species count'	3
iv)	'species ID'	4	A	'species count'	4
v)	'species ID'	5	A	'species count'	5

Note that in the above there are only two GF3 parameter codes viz: one for 'species ID' and one for 'species count' - the codes identifying the particular species are contained in the 5 header parameters in the 'user-defined area'. The parameter discriminator in bytes 11-13 is not really required as each of the 'species ID' parameters is uniquely identified by having a unique secondary parameter, i.e. species count 1, species count 2, etc.

ANNEX I

GF3 CODE TABLE 1 : IOC COUNTRY CODE (1987 VERSION)

(Tape Header Record, bytes 7-8
File/Series Header Record, bytes 12-13)

The IOC Country Code is intended purely for oceanographic data exchange purposes. The original version of the code was approved by the Seventh Session of the IOC Working Committee on International Oceanographic Data Exchange, and was published in 1976 in the Manual on International Oceanographic Data Exchange (Fourth Edition), IOC Manuals and Guides No. 9. Its updating and maintenance is provided by the IOC Group of Experts on Technical Aspects of Data Exchange. At the Tenth Session of the IOC Working Committee on International Oceanographic Data Exchange (Hamburg, 5-13 August, 1981), the Group of Experts agreed that the code should be updated to include all IOC Member States. These updates are included in the following tables, identified by an '*'. In 1987 a further 10 IOC member states were added to the code table - these are identified by an '#'. .

TABLE 1A : IOC COUNTRY CODE (SORTED BY COUNTRY)

<u>Code</u>	<u>Country</u>	<u>Code</u>	<u>Country</u>
72	Albania	FJ	*Fiji
AL	Algeria	34	Finland
AN	#Angola	35	France
08	Argentina	GA	*Gabon
09	Australia	GM	#Gambia
10	Austria	96	German Democratic Republic
BH	*Bahamas	06	Germany, Federal Republic of
BN	#Bangladesh	GH	Ghana
BR	#Barbados	36	Greece
11	Belgium	37	Guatemala
DA	Benin (Dahomey)	GU	Guinea
13	Bolivia	GN	#Guinea - Bissau
14	Brazil	GY	*Guyana
15	Bulgaria	38	Haiti
12	Burma	HO	Honduras
17	*Cameroon	46	Iceland
18	Canada	41	India
CV	#Cape Verde	42	Indonesia
20	Chile	IN	Intergovernmental/International
21	China	44	*Iran
22	Colombia	43	*Iraq
RC	Congo	45	Ireland
CR	Costa Rica	47	Israel
IC	Cote d'Ivoire	48	Italy
CU	Cuba	JA	Jamaica
CY	*Cyprus	49	Japan
26	Denmark	50	*Jordan
70	Dominican Republic	KE	*Kenya
28	Ecuador	KR	*Korea, Democratic People's Republic of
27	Egypt, Arab Republic of	24	Korea, Republic of
75	El Salvador	KU	*Kuwait
ET	*Ethiopia	52	Lebanon

<u>Code</u>	<u>Country</u>	<u>Code</u>	<u>Country</u>
53	*Libyan Arab Jamihiriya	S0	#Solomon Islands
55	Madagascar	SM	*Somalia
MS	Malaysia	91	South Africa
ML	*Malta	29	Spain
MU	*Mauritania, Islamic Republic of	19	Sri Lanka
MA	*Mauritius	SU	Sudan
57	Mexico	79	*Surinam
MO	Monaco	77	Sweden
56	Morocco	78	*Switzerland
MZ	Mozambique	80	*Syrian Arab Republic
64	Netherlands	ZA	Tanzania, United Republic of
59	New Caledonia	86	Thailand
61	New Zealand	87	*Togo
NC	*Nicaragua	TN	*Tonga
NI	Nigeria	TT	*Trinidad and Tobago
58	Norway	88	Tunisia
62	Pakistan	89	Turkey
PA	Panama	UR	#Ukrainian Soviet Socialist Republic
65	Peru	90	Union of Soviet Socialist Republics
66	Philippines	UA	*United Arab Emirates
67	Poland	74	United Kingdom
68	Portugal	31	United States of America
QA	*Qatar	(32)	United States of America (alternative code)
OM	#Oman	99	Unknown/unspecified
73	Romania	92	Uruguay
SA	*Saudi Arabia	93	Venezuela
SE	Senegal	94	Vietnam
SC	*Seychelles, Republic of	WS	*Western Samoa
SL	Sierra Leone	YM	#Yemen
SI	*Singapore	95	Yugoslavia

TABLE 1B : IOC COUNTRY CODE (SORTED BY CODE)

<u>Code</u>	<u>Country</u>	<u>Code</u>	<u>Country</u>
06	Germany, Federal Republic of	29	Spain
08	Argentina	31	United States of America
09	Australia	(32)	United States of America (alternative code)
10	Austria	34	Finland
11	Belgium	35	France
12	Burma	36	Greece
13	Bolivia	37	Guatemala
14	Brazil	38	Haiti
15	Bulgaria	41	India
17	*Cameroon	42	Indonesia
18	Canada	43	*Iraq
19	Sri Lanka	44	*Iran
20	Chile	45	Ireland
21	China	46	Iceland
22	Colombia	47	Israel
24	Korea, Republic of	48	Italy
26	Denmark	49	Japan
27	Egypt, Arab Republic of	50	*Jordan
28	Ecuador	52	Lebanon

Code Country

53 *Libyan Arab Jamaihiriya
55 Madagascar
56 Morocco
57 Mexico
58 Norway
59 New Caledonia (France)
61 New Zealand
62 Pakistan
64 Netherlands
65 Peru
66 Philippines
67 Poland
68 Portugal
70 Dominican Republic
72 Albania
73 Romania
74 United Kingdom
75 El Salvador
77 Sweden
78 *Switzerland
79 *Suriname
80 *Syrian Arab Republic
86 Thailand
87 *Togo
88 Tunisia
89 Turkey
90 Union of Soviet Socialist
Republics
91 South Africa
92 Uruguay
93 Venezuela
94 Vietnam
95 Yugoslavia
96 German Democratic Republic
99 Unknown/unspecified

AL Algeria
AN #Angola
BH *Bahamas
BN #Bangladesh
BR #Barbados
CR Costa Rica
CU Cuba
CV #Cape Verde

Code Country

CY *Cyprus
DA Benin (Dahomey)
ET *Ethiopia
FJ *Fiji
GA *Gabon
GH Ghana
GM #Gambia
GN #Guinea - Bissau
GU Guinea
GY *Guyana
HO Honduras
IC Cote d'Ivoire
IN Intergovernmental/International
JA Jamaica
KE *Kenya
KR *Korea, Democratic People's Republic of
KU *Kuwait
MA *Mauritius
ML *Malta
MO Monaco
MS Malaysia
MU *Mauritania, Islamic Republic of
MZ Mozambique
NC *Nicaragua
NI Nigeria
OM #Oman
PA Panama
QA *Qatar
RC Congo
SA *Saudi Arabia
SC *Seychelles, Republic of
SE Senegal
SI *Singapore
SL Sierra Leone
SM *Somalia
SO #Solomon Islands
SU Sudan
TN *Tonga
TT *Trinidad and Tobago
UA *United Arab Emirates
UR #Ukrainian Soviet Socialist Republic
WS *Western Samoa
YM #Yemen, Arab Republic of
ZA Tanzania, United Republic of

ANNEX II

GF3 CODE TABLE 2 : GF3 COMMON CHARACTER SET

(Tape Header Record, bytes 162-213)

When GF3 was first developed, one of the most difficult problems in exchanging magnetic tapes was the incompatibility of tape codes. To overcome this problem a restricted common character set was adopted and included as bytes 162 to 213 of the tape header record to serve as a translation table between the code used to write the tape and that used on the recipient's system. By this technique any tape could be read without prior knowledge of the tape code used to write it. In recent years most tape systems have standardised on one of two codes viz EBCDIC and ASCII, and efficient system utilities are usually available to translate between the two codes. However, the translation table is still included in the tape header record so as to serve as a confirmation of the code system actually used in writing the tape, and in the event that translations into codes other than ASCII or EBCDIC are required.

The GF3 character set continues to be restricted to those characters given in the translation table - this is the only common character set that exists between different countries, particularly those that also include non-Roman alphabetic letters in their ASCII or EBCDIC character sets. However, in the next release of the GF3-Proc software it is planned to expand the character set so as to allow the user to include the lower case letters a to z in the plain language text areas (i.e. line images 4 to 24 of the tape header record, line images 6 to 24 of the file header record or all line images of the plain language record) of GF3 records. This expansion is intended only for the use of GF3 for data archiving or for exchange when both the exchanging parties are agreeable.

The GF3 character set is listed out below (under the display heading) against its position in the tape header translation table, together with its EBCDIC and ASCII equivalents in hexadecimal (hex), octal and decimal (dec) form.

Byte No	Display	<u>EBCDIC Equivalent</u>			<u>ASCII Equivalent</u>				Byte No
		Hex	Octal	Dec	Display	Hex	Octal	Dec	
162	1	F1	361	241	1	31	061	49	162
163	2	F2	362	242	2	32	062	50	163
164	3	F3	363	243	3	33	063	51	164
165	4	F4	364	244	4	34	064	52	165
166	5	F5	365	245	5	35	065	53	166
167	6	F6	366	246	6	36	066	54	167
168	7	F7	367	247	7	37	067	55	168
169	8	F8	370	248	8	38	070	56	169
170	9	F9	371	249	9	39	071	57	170
171	0	F0	360	240	0	30	060	48	171
172	=	7E	176	126	=	3D	075	61	172
173	:	7A	172	122	:	3A	072	58	173
174	>	6E	156	110	>	3E	076	62	174
175	blank (space)	40	100	64	blank (space)	20	040	32	175
176	/	61	141	97	/	2F	057	47	176
177	S	E2	342	226	S	53	123	83	177
178	T	E3	343	227	T	54	124	84	178
179	U	E4	344	228	U	55	125	85	179

continued		<u>EBCDIC Equivalent</u>			<u>ASCII Equivalent</u>				
Byte No	Display	Hex	Octal	Dec	Display	Hex	Octal	Dec	Byte No
180	V	E5	345	229	V	56	126	86	180
181	W	E6	346	230	W	57	127	87	181
182	X	E7	347	231	X	58	130	88	182
183	Y	E8	350	232	Y	59	131	89	183
184	Z	E9	351	233	Z	5A	132	90	184
185	,	6B	153	107	,	2C	054	44	185
186	(4D	115	77	(28	050	40	186
187	-	60	140	96	-	2D	055	45	187
188	J	D1	321	209	J	4A	112	74	188
189	K	D2	322	210	K	4B	113	75	189
190	L	D3	323	211	L	4C	114	76	190
191	M	D4	324	212	M	4D	115	77	191
192	N	D5	325	213	N	4E	116	78	192
193	O	D6	326	214	O	4F	117	79	193
194	P	D7	327	215	P	50	120	80	194
195	Q	D8	330	216	Q	51	121	81	195
196	R	D9	331	217	R	52	122	82	196
197	*	5C	134	92	*	2A	052	42	197
*198	}	D0	320	208]	5D	135	93	198
199	;	5E	136	94	;	3B	073	59	199
200	+	4E	116	78	+	2B	053	43	200
201	A	C1	301	193	A	41	101	65	201
202	B	C2	302	194	B	42	102	66	202
203	C	C3	303	195	C	43	103	67	203
204	D	C4	304	196	D	44	104	68	204
205	E	C5	305	197	E	45	105	69	205
206	F	C6	306	198	F	46	106	70	206
207	G	C7	307	199	G	47	107	71	207
208	H	C8	310	200	H	48	110	72	208
209	I	C9	311	201	I	49	111	73	209
210	.	4B	113	75	.	2E	056	46	210
211)	5D	135	93)	29	051	41	211
*212	{	C0	300	192	[5B	133	91	212
213	<	4C	114	76	<	3C	074	60	213

*Note that the characters [and] present in the ASCII set have no equivalent in EBCDIC and should be represented in the EBCDIC version of the translation table by the characters { and } respectively. It is strongly recommended that these characters should not be used as part of the GF3 character set.

ANNEX III

GF3 CODE TABLE 3 : PLATFORM TYPE CODE

(File/Series Header Record, bytes 82-83, 162-163)
CODE FORM D₁D₂

TYPE OF PLATFORM	CODE D ₁ \ D ₂	SUB DIVISION OF PLATFORM TYPE											
		0	1	2	3	4	5	6	7	8	9		
UNKNOWN	0	UNKNOWN OR NOT SPECIFIED											
LAND/ SEA FLOOR	1		SEA FLOOR: FIXED	SEA FLOOR: MOBILE	BEACH/ INTERTIDAL ZONE	LAND/ ONSHORE: FIXED	LAND/ ONSHORE: MOBILE	OFFSHORE STRUCTURE e.g. Oil Rig	COASTAL STRUCTURE e.g. Pier, Lighthouse, rock				
SUBMERSIBLE	2		MANNED	UNMANNED: MOBILE	UNMANNED: TOWED								
SHIP	3		RESEARCH SHIP	SHIP OF OPPORTUNITY	SMALL CRAFT e.g. Dinghy	FIXED POSITION e.g. Lightvessel							
BUOY/ MOORING	4		SURFACE: MOORED	SURFACE: DRIFTING	SUBSURFACE: MOORED	SUBSURFACE: DRIFTING	SUBSURFACE: VERTICAL PROFILING						
BALLOON	5		FREE RISING (VERTICAL)	FREE FLOATING (HORIZONTAL)	TETHERED								
AIRCRAFT/ SATELLITE/ ROCKET	6		RESEARCH AIRCRAFT	OTHER AIRCRAFT	ROCKET: NON ORBITING	SATELLITE: GEO- STATIONARY ORBIT	SATELLITE: NON GEO- STATIONARY ORBIT	MANNED SPACECRAFT					
UNASSIGNED	7												
'GRID'	8		GEOGRAPHIC	CARTESIAN									
OTHER	9		ICE ISLAND										

PLATFORM TYPE CODE

ANNEX III

ANNEX IV

GF3 CODE TABLE 4 : SPECIFIC PLATFORM CODE

(File/Series Header Record, bytes 93-101, 173-181)

The exact usage of this field is dependent on the 'Identification of the code system' entry in the byte immediately preceding the field (i.e. byte 92 or 172 respectively).

CODE SYSTEM IDENTIFIER (byte 92/172)	CODE SYSTEM	SPECIFIC PLATFORM CODE
1	ITU Call Sign	For ships with call signs consult the ITU list of ship's call signs e.g. R.R.S. Discovery = 'GLNE'
2	WMO/IOC	Reserved for future use
3	ICES Ship Code	First 4 bytes set to 'ICES' - remainder expressed in form ccsss where cc = 2 character IOC country code (see Table 1) and sss = 3 digit ICES ship code within that country. Where the ICES ship code is only 2 digits the last byte is set as blank e.g. R.R.S. Discovery = 'ICES7431 '
4	IOC/NODC	First 3 bytes set to 'cc-' where cc = 2 character IOC country code (see Table 1) identifying the country of the national oceanographic data centre whose platform code is in use. The remaining bytes contain the specific platform code padded out with blanks if necessary e.g. R.R.S. Discovery in the USA NODC ship code would be expressed as '31-74DI '
5	WMO buoy identifier	First 4 bytes set to 'BUOY' - remaining 5 bytes set to the WMO buoy identifier $A_1b_wn_1n_2n_3n_4$ where: A_1 = WMO Regional Association area in which buoy has been deployed (WMO Code Table 0161) b_w = sub-area of A_1 (see WMO Code Table 0161) $n_1n_2n_3n_4$ = WMO serial number of buoy within A_1b_w
9	Other national or local identifier	Free format

ANNEX V

GF3 CODE TABLE 5 : MODIFIED I.H.B. OCEAN/SEA AREA CODE

(File/Series Header Record, bytes 353-355)

This code is based on I.H.B. Special Publication No.23 (Third Edition, 1953) - 'Limits of Oceans and Seas', which contains a precise definition of each area. Modifications to the I.H.B. system include the addition of sub-divisions for the major oceans and of entries for the Southern Ocean (Southern limit - the Antarctic Continent. Its northern limit is dependent on the oceanographic conditions e.g. Antarctic Convergence, and is typically 50°S) - these additions are flagged below by an '*'.

<u>Code</u>	<u>Ocean/Sea Area</u>	<u>Code</u>	<u>Ocean/Sea Area</u>
010	Baltic Sea	380	Gulf of Aden
01A	Gulf of Bothnia	390	Arabian Sea
01B	Gulf of Finland	400	Gulf of Oman
01C	Gulf of Riga	410	Gulf of Iran (Persian Gulf)
020	Kattegat, Sound and Belts	420	Laccadive Sea
030	Skagerrak	430	Bay of Bengal
040	North Sea	440	Andaman or Burma Sea
050	Greenland Sea	450	Indian Ocean
060	Norwegian Sea	45A	Mozambique Channel
070	Barentsz Sea	460	Malacca and Singapore Straits
080	White Sea	46A	Malacca Strait
090	Kara Sea	46B	Singapore Strait
100	Laptev (or Nordenskjold) Sea	470	Gulf of Thailand (Siam)
110	East Siberian Sea	480	East Indian Archipelago (Indonesia)
120	Chukchi Sea	48A	Sulu Sea
130	Beaufort Sea	48B	Celebes Sea
140	The Northwestern Passages	48C	Molukka Sea
14A	Baffin Bay	48D	Gulf of Tomini
150	Davis Strait	48E	Halmahera Sea
15A	Labrador Sea	48F	Ceram Sea
160	Hudson Bay	48G	Banda Sea
16A	Hudson Strait	48H	Arafura Sea
170	Arctic Ocean	48I	Timor Sea
17A	Lincoln Sea	48J	Flores Sea
180	Inner Seas off the West Coast of Scotland	48K	Gulf of Boni
190	Irish Sea and St. George's Channel	48L	Bali Sea
200	Bristol Channel	48M	Makassar Strait
210	English Channel	48N	Java Sea
220	Bay of Biscay	48P	Savu Sea
230	North Atlantic Ocean	490	South China Sea (Nan Hai)
*23A	NE Atlantic (Limit 40°W)	500	Eastern China Sea (Tung Hai)
*23B	NW Atlantic (Limit 40°W)	510	Yellow Sea (Hwang Hai)
240	Gulf of St. Lawrence	520	Japan Sea
250	Bay of Fundy	530	Inland Sea (Seto Naikai)
260	Gulf of Mexico	540	Sea of Okhotsk
270	Caribbean Sea	550	Bering Sea
280	Mediterranean Sea	560	Philippine Sea
28A	Western Basin	570	North Pacific Ocean
28B	Eastern Basin	*57A	NE Pacific (Limit 180°)
28C	Strait of Gibraltar	*57B	NW Pacific (Limit 180°)
28D	Alboran Sea	580	Gulf of Alaska
28E	Balearic Sea (or Iberian Sea)	590	Coastal Waters of SE Alaska and British Columbia
28F	Ligurian Sea	600	Gulf of California
28G	Tyrrhenian Sea	610	South Pacific Ocean
28H	Ionian Sea	*61A	SE Pacific (Limit 140°W)
28I	Adriatic Sea	*61B	SW Pacific (Limit 140°W)
28J	Aegean Sea (The Archipelago)	620	Great Australian Bight
290	Sea of Marmara	62A	Bass Strait
300	Black Sea	630	Tasman Sea
310	Sea of Azov	640	Coral Sea
320	South Atlantic Ocean	650	Solomon Sea
*32A	SE Atlantic (Limit 20°W)	660	Bismarck Sea
*32B	SW Atlantic (Limit 20°W)	*700	Southern Ocean
330	Rio de La Plata	*70A	Atlantic Sector of '700'
340	Gulf of Guinea	*70B	Indian Ocean Sector of '700'
350	Gulf of Suez	*70C	Pacific Sector of '700'
360	Gulf of Aqaba	999	Land Areas
370	Red Sea		

ANNEX VI

GF3 CODE TABLE 6 : VALIDATION FLAG

(File/Series Header Record, byte 358)

<u>Code</u>	<u>Descriptor</u>
blank	- unspecified or quality control check has not been made
A	- <u>A</u> ceptable: data found acceptable during quality control checks
C	- <u>C</u> autious: certain aspects of the data are considered suspect - consult plain language records following file/series header record for further details

The above table applies to the file/series as a whole. Individual values at the data cycle level may be flagged using the parameter 'FFFF7AAN' (as described in GF3 Code Table 7 see Annex VIII) in conjunction with the following code table:-

<u>Code</u>	<u>Descriptor</u>
blank	- unspecified or quality control check has not been made
A	- <u>A</u> ceptable: data found acceptable during quality control checks
S	- <u>S</u> spect Value: data considered suspect (but not replaced) by the data originator on the basis of either quality control checks or recorder/instrument/platform performance
Q	- <u>Q</u> uestionable Value: data considered suspect (but not replaced) during quality control checks by persons other than those responsible for its original collection e.g. a data centre
R	- <u>R</u> eplaced Value: erroneous or missing data has been replaced by estimated or interpolated value - method by which replacement values have been derived should be described in plain language records
M	- <u>M</u> issing Value: original data erroneous or missing

ANNEX VII

GF3 CODE TABLE 7 : PARAMETER CODE

(Definition Record - line image bytes 3-10 and 67-74)

STANDARD CODES

The parameter code tables for GF3 are continually growing and new standard codes are assigned to meet the demand for the exchange and archival of more and more parameters. The code tables presented in this Annex are not, and cannot be, up to date. Users are encouraged to contact RNODC (Formats) on a regular basis to obtain the latest and most complete versions of the code tables. So as to maintain compatibility with data already stored in GF3, the updating of the code tables will not involve the deletion or alteration of existing entries. Embedded within the structure of the parameter code (see next page) is a flag to indicate whether the code has been accepted by RNODC (Formats) as a standard code.

USER-DEFINED CODES

The absence from the code table of an entry for a particular parameter should, in no way, inhibit the user from storing that parameter in GF3. The structure of the parameter code has been designed to permit and encourage the assignment of parameter codes by the user when no standard GF3 code is available. However, when a parameter code is user assigned, the user must include a clear definition of the parameter, its code and units in a GF3 plain language comments area. Users are encouraged to use the standard codes whenever possible and, before assigning a user code, to check whether an appropriate code already exists in the standard tables.

PARAMETER CODE TABLE

The standard GF3 parameter codes are presented in this volume as ten separate tables:

Table 7A: General purpose	Table 7F: Waves
Table 7B: Date and time within day	Table 7G: Meteorology
Table 7C: Time and frequency	Table 7H: Geophysics
Table 7D: Position and navigation	Table 7I: Chemistry
Table 7E: Physical oceanography	Table 7J: Special purpose

Quick look up indexes to the parameter code are given in Annexes VIII and IX - Annex VIII providing a simple index based on the first four characters of the code (i.e. PPPP) with Annex IX providing an index based on the dimensional exponents of each parameter. Annex IX is designed to enable the user to ascertain quickly whether or not a particular parameter has been assigned a standard GF-3 parameter code. It is anticipated that this index will be found to be particularly useful as the code table expands.

STRUCTURE OF THE GF3 PARAMETER CODE

The GF3 parameter code is structured as an eight character field in the form PPPPKMMS

where PPPP = PARAMETER IDENTIFIER
 K = KEY FOR USER DEFINED OPTIONS
 MM = METHOD/PARAMETER QUALIFIER
 S = SPHERE IDENTIFIER

PPPP (PARAMETER IDENTIFIER) is a four character upper case alphabetic (A-Z) code which identifies the parameter. The assignment of the code implies a clear definition of the parameter and the units in which it is stored. In the standard code table the units are selected to conform with SI (Système Internationale).

K (KEY FOR USER DEFINED OPTIONS) is a one digit key to identify those elements of the parameter code that are part of the standard code table and those that are user-defined:

<u>K</u>		
7	P,M,U all standard	
6	P,M standard, U non standard	where P = parameter identifier
5	P,U standard, M non standard	M = method/parameter qualifier
4	P standard, M,U non standard	U = parameter units
2	P,M,U all non standard	

K=7 if the parameter identifier (and hence the definition of the parameter), method/parameter qualifier and units all conform precisely with entries in the standard code table.

K=6 or 4, non standard units U implies units differing from those specified for the parameter in the standard code table.

K=5 or 4, non standard M implies the use of a user-defined method/parameter qualifier in conjunction with a standard parameter identifier.

K=2 implies that the parameter identifier (and definition of the parameter), method/parameter qualifier and units are all defined by the user.

It is essential that all of the user-defined elements are clearly described in plain language records accompanying the data, preferably at tape or file level. For K=2, this description should include a clear definition of the parameter. Whenever possible, user supplied units should conform with the SI system - if necessary the scaling factors (in the definition record) may be used to convert from non standard units. (See section 5.2.4).

MM (METHOD/PARAMETER QUALIFIER) is a two character upper case alphabetic (A-Z) code identifying the method used to measure the parameter. Alternatively, it may be used as a qualifier of the parameter itself. It is coded with respect to the parameter identifier PPPP except when it is unspecified when it is always set to 'XX'.

S (SPHERE IDENTIFIER) is a one character alphabetic code to identify the sphere in which the parameter is measured:

<u>S</u>		<u>S</u>	
A	atmosphere	G	lithosphere
B	atmosphere/hydrosphere interface	H	interstitial
C	atmosphere/lithosphere interface	J	biosphere (internal to organisms)
D	hydrosphere	N	not applicable (e.g. coordinates)
E	hydrosphere/lithosphere interface	X	unspecified

The interface spheres are used only where the parameter refers to something being transported through the interface, or where reference is made to measurements on both sides of the interface (e.g. air-sea temperature difference).

TABLE 7A

GENERAL PURPOSE PARAMETERS

Parameters in this table are organised under the headings:

- i) QUALITY CONTROL FLAGS
- ii) SPECIAL FUNCTIONS
- iii) DATA STRUCTURE EXTENSIONS
- iv) OTHER PARAMETERS

i) PPPP K MM § QUALITY CONTROL FLAGS

FFFF 7 -- N QUALITY CONTROL FLAG

This indicates a quality control flag applicable to the value of the immediately preceding parameter in the 'user-defined area'. The method code MM indicates the flag code table in use:-

7 AA Flag coded as in GF3 Code Table 6 as follows:-

blank Unspecified or quality control check has not been made

A Acceptable: data found acceptable during quality control checks

S Suspect Value: data considered suspect (but not replaced) by the data originator on the basis of either quality control checks or recorder/instrument/platform performance

Q Questionable Value: data considered suspect (but not replaced) during quality control checks by persons other than those responsible for its original collection e.g. a data centre

R Replaced Value: erroneous or missing data has been replaced by estimated or interpolated value - method by which replacement values have been derived should be described in plain language records

M Missing Value: original data erroneous or missing

7 GG Flag coded according to the IGOSS system as follows:-

0 No quality control (QC) has been performed on the value

1 QC performed: value appears correct

2 QC performed: value appears inconsistent with other values

3 QC performed: value appears doubtful

4 QC performed: value appears erroneous

5 Value has been changed as a result of QC

6-8 Reserved for future use

9 Value of the parameter is missing

6 XX User defined flag code in use - consult plain language records for details

QPOS 7 -- N QUALITY CONTROL FLAG FOR GEOGRAPHIC POSITION

One character quality control flag applicable to the latitude and longitude recorded for a given geographic location. For series at a fixed position it refers to the coordinates given in characters 270-284 of the series header record - otherwise it relates to individual locations recorded in a 'user-defined area'. The method code MM indicates the flag code table in use:

AA Flag coded as for parameter FFFF7AAN above
GG Flag coded as for parameter FFFF7GGN above

QTIM 7 -- N QUALITY CONTROL FLAG FOR SERIES DATE/TIME

One character quality control flag applicable to start/end date/time entries given in bytes 242 to 269 of the series header record. The method code MM indicates the flag code table in use:

AA Flag coded as for parameter FFFF7AAN above
GG Flag coded as for parameter FFFF7GGN above

GGQF 7 -- N QUALITY CONTROL FLAGS FOR DATE, TIME, POSITION AND SEA FLOOR DEPTH

GG Contains a sequence of six single character quality control flags associated respectively with the values of: day (c8-9), month (c6-7), time (c10-13), latitude (c30-36), longitude (c37-44) and sea floor depth (c48-53) in that order, as recorded in line image 4 of the series header record. The method code MM indicates the flag code table in use:

AA Flag coded as for parameter FFFF7AAN above
GG Flag coded as for parameter FFFF7GGN above

ii) PPPP K MM \$ SPECIAL FUNCTIONS

EEEE 7 XX N DECIMAL EXPONENT

This power of ten is to be attached to the value of the immediately succeeding parameter in the 'user-defined area' after application of scale factors associated with that parameter (as in line bytes 49-64 of the Definition Record). For example, if two successive parameters EEEE and ABCD contain values (after application of scale factors) of '2' and '123' respectively, the result should be interpreted as a value of 123×10^2 for the parameter ABCD.

SDEV 7 XX N STANDARD DEVIATION OF PRECEDING PARAMETER (units as for preceding parameter)

The standard deviation of the preceding parameter in the 'user-defined area' - not necessarily the immediately preceding parameter, e.g. in cases where the preceding parameter is followed by a quality control flag. To avoid ambiguity it is recommended that, in the definition line image defining SDEV, the secondary parameter code should reference the parameter to which the standard deviation applies.

PVAR 7 XX N VARIANCE OF PRECEDING PARAMETER (squared units of preceding parameter)

The variance of the preceding parameter in the 'user-defined area' - not necessarily the immediately preceding parameter, e.g. in cases where the preceding parameter is followed by a quality control flag. To avoid ambiguity it is recommended that, in the definition line image defining PVAR, the secondary parameter code should reference the parameter to which the variance applies.

iii) PPPP K MM S DATA STRUCTURE EXTENSIONS

The GF3 system involves a data hierarchy of four levels i.e. data cycle level, series level, file level, and tape (or dataset) level. In fact, two additional levels of hierarchy exist around the data cycle level viz:

- 1) Through the use of header parameters in the data cycle records it is possible to build up discrete sets of data cycles within a data series.
- 2) Individual data cycles can themselves be designed to contain repeating groups of parameters.

The following four parameters, CCCC, CFLG, PAIR and CHAN may be used to support these additional structures:

PPPP K MM S

CCCC 7 -- N DATA CYCLE OVERFLOW INDICATOR

This flag is used as a 'header parameter' for indicating whether or not data cycles overflow a 'user-defined area'

AA One character flag coded as follows:-

- 0 : data cycles completed within this record
- 1 : data cycles continued on the next record

Note on usage: This parameter was originally created so as to enable data cycles to overflow the 'user-defined area' of a series header record - this function is now supported by the series header continuation flag introduced into byte 397 of the series header record during the updating of GF3 to version GF3.2. The parameter is now used primarily with data cycle records to enable series to be built up as sets of data cycles, with each new set of data cycles starting with a new data cycle record. 'Header parameters' are used for information common to each individual set of data cycles, and the parameter CCCC indicates whether the set of data cycles overflows the data cycle record. When the overflow condition occurs, the 'header parameters' are repeated on the following data cycle record before continuing the data cycles.

Example of usage: A time series of wave spectra with each spectrum made up as a frequency series of spectral density(s). Each spectrum would start with a new data cycle record with 'header parameters' common to the spectrum as a whole e.g. date and time, digital sampling frequency, bandwidth and duration of sampling, while the data cycles would include parameters such as frequency and spectral density(s).

CFLG 7 -- N DATA CONTINUATION FLAG

Flag to indicate whether a data cycle represents the start of a new data sequence or the continuation of the sequence from the previous data cycle.

AA One character flag coded as follows:

- 0 : data cycle represents the start of a new data sequence
- 1 : data cycle represents the continuation of a data sequence

Note on usage: The usage of this parameter is best illustrated by an example. Consider the case of a digitized bathymetric contour chart with individual contours stored as a labelled stream of paired geographic latitude and longitude values. Each data sequence (i.e. contour) will consist of a depth value followed by a sequence of paired latitude and longitude values. However, the number of paired values is highly variable - varying from a minimum of 3 for small enclosed contours to a potentially very large number for long contour streams. A practical solution to this problem is to break the contour into segments and to map these segments into data cycles containing the parameters: contour depth, CFLG, PAIR and a fixed number (say 5) of paired latitude and longitude values. Individual contours would then consist of one or more data

cycles, the parameter CFLG would maintain the link between the data cycles (i.e. the continuity of the contour) while the parameter PAIR would cover for short data cycles at the end of each sequence. The next contour stream in the series would then start in the next data cycle (irrespective of data cycle record boundaries) with CFLG reset to 0.

PAIR 7 XX N COUNT OF PARAMETER PAIRS IN DATA CYCLE

This parameter may be used in cases where the data cycles contain a variable number of repeated pairs of parameters and explicit control is required in the processing of these data. In such cases the data cycle will be defined to contain a fixed (i.e. maximum) number, n, of parameter pairs with each parameter occurrence (i.e. 2n in total) defined as a 'data cycle parameter'. The parameter PAIR may then be used to indicate how many parameter pairs in the data cycle contain actual data - the remaining parameter pairs being filled with the appropriate null values. Note that the use of this parameter implies a certain amount of redundancy as one can always deduce the number of parameter pairs in each data cycle by determining the number of pairs containing valid data as opposed to null values. Its use is therefore optional.

CHAN 7 XX N NUMBER OF SENSOR CHANNELS

This parameter is used primarily in standard GF3 subsets designed to accommodate data from a variable number of sensor channels - the subset itself being standardised to a predefined maximum number of channels. The parameter CHAN refers to the actual number of channels containing valid data in a given data series - the remaining channels being filled with appropriate null values. Its use is optional and similar to that of parameter PAIR.

MMMM 7 -- N METHOD CODE IN USER DEFINED AREA

This indicates that the method code MM appropriate to a specific stored parameter instead of being entered in bytes 8-9 of the Definition Record line image defining that stored parameter, is entered in a 'user-defined area' i.e. it is itself a header or data cycle parameter.

The Definition Record line image defining this method code parameter has bytes 3-10 set to MMMM7--N (-- being entered as below) and bytes 67-74 (secondary parameter code) set to the code of the parameter to which the method code parameter is to apply.

The code table in use is defined as follows:-

- 7 AA Standard two character method code appropriate to the secondary parameter
- 7 FF First character only of the standard two character method code appropriate to the specified secondary parameter (at present restricted to use with parameters TEMP, PSAL, SSAL, PRES, DEPH)
- 6 XX User defined method code in use - consult plain language records for details

iv) PPPP K MM § OTHER PARAMETERS

TEXT 7 XX N PLAIN LANGUAGE TEXT

Used for creating plain language area in the 'user-defined area' of a series header record

IDEN 7 XX N DATA IDENTIFIER

Used in cases where an identifier is required to label data within a data series with, for example, a measurement, cast, sample, station, leg or scan number - need not be confined to numeric identifiers.

PPPP K MM S

PLAT 7 -- N PLATFORM IDENTIFIER

Used only if platform identification is required within a 'user-defined area' rather than in lines 002/003 of the series header record e.g. when data from different platforms are merged in the same series and there is a need to retain the platform identifier. The platform identifier is expressed according to the system identified in MM:-

- CS ITU call sign
- BY WMO buoy identifier A₁b_wn_bn_bn_bn_b
- ST WMO station identifier IIIII
- PL Platform name or other free format text
- UU User specified code (as defined in accompanying plain language record)

TABLE 7B
DATE AND TIME WITHIN DAY

PPPP K MM S

Note: Whenever possible date and time should be expressed in G.M.T. However, if it is necessary to use local time (i.e. zonal time) then the Time Zone must also be provided using the following parameter:-

ZONE 7 XX N TIME ZONE CORRECTION (hours)

Defined as the number of hours to be added to convert the stored date/time parameters to G.M.T.

The definition of all the following parameters in this section are qualified according to entry in MM thus:-

ZT Time of observation (G.M.T.)
ZS Time of observation start (G.M.T.)
ZE Time of observation end (G.M.T.)
LT Time of observation (local time)
LS Time of observation start (local time)
LE Time of observation end (local time)

YEAR 7 -- N CALENDAR YEAR
-- MM as above

MNTH 7 -- N CALENDAR MONTH (MM) WITHIN YEAR
-- MM as above

DATE 7 -- N DATE WITHIN YEAR IN FORMAT MMDD
Where MM = calendar month and DD = day of month
-- MM as above

DAYS 7 -- N DAY NUMBER WITHIN YEAR (Jan 1st = 1)
-- MM as above

TIME 7 -- N TIME WITHIN DAY IN FORMAT HHMMSS
Where HH = hours, MM = minutes and SS = seconds
-- MM as above

HHMM 7 -- N TIME WITHIN DAY IN FORMAT HHMM
Where HH = hours and MM = minutes
-- MM as above

HOUR 7 -- N HOURS WITHIN DAY
-- MM as above

MINS 7 -- N MINUTES WITHIN HOUR
-- MM as above

SECS 7 -- N SECONDS WITHIN MINUTE
-- MM as above

TABLE 7C
TIME AND FREQUENCY

i) PPPP K MM § TIME

Where appropriate the definition of parameters in this section are qualified according to the entry in MM

ETHR 7 XX N ELAPSED TIME (HOURS)

ETMN 7 XX N ELAPSED TIME (MINUTES)

ETSC 7 XX N ELAPSED TIME (SECONDS)

DRHR 7 -- N DURATION (HOURS)

PR Duration of processed observation: total time period over which sampling was undertaken in order to produce the stored observation

SS Duration of individual sample: used mainly in cases where the processed observation is itself derived/extracted from a number of discrete individual samples

DRMN 7 -- N DURATION (MINUTES)

-- MM as for DRHR

DRSC 7 -- N DURATION (SECONDS)

-- MM as for DRHR

NTHR 7 -- N INTERVAL (HOURS)

PR Interval of processed observations - usually the same as data cycle interval

SS Original sampling/digitization interval - used mainly in cases where the processed observation may be derived/extracted from higher resolution data

NTMN 7 -- N INTERVAL (MINUTES)

-- MM as for NTHR

NTSC 7 -- N INTERVAL (SECONDS)

-- MM as for NTHR

ii) PPPP K MM § FREQUENCY

FREQ 7 -- N FREQUENCY (hertz)

PR Frequency of processed observations

SS Original sampling/digitization frequency

SPCF 7 XX N FREQUENCY OF SPECTRAL COMPONENT (hertz)

BAND 7 XX N BANDWIDTH OF SPECTRAL ANALYSIS (hertz)

BEST 7 XX N BANDWIDTH OF SPECTRAL COMPONENT (hertz)

Frequency bandwidth over which the specified spectral component has been estimated - especially where the component is the frequency average of a number of discrete spectral estimates as produced by the original spectral analysis

HIGF 7 XX N HIGH FREQUENCY CUT OFF FOR INTEGRATION UNDER SPECTRUM (hertz)

LOWF 7 XX N LOW FREQUENCY CUT OFF FOR INTEGRATION UNDER SPECTRUM (hertz)

TABLE 7D

POSITION / NAVIGATION

Parameters in this table are organised under the headings:

- i) GEOGRAPHIC COORDINATES
- ii) RELATIVE COORDINATES
- iii) PLATFORM MOTION/ORIENTATION

1) PPPP K MM § GEOGRAPHIC COORDINATES

MAGN 7 XX N MAGNETIC VARIATION FROM TRUE NORTH (degrees) east +ve

ALTG 7 XX N HEIGHT/ALTITUDE ABOVE GROUND LEVEL (metres) upwards +ve

ALTS 7 XX N HEIGHT/ALTITUDE ABOVE MEAN SEA LEVEL (metres) upwards +ve

HGHT 7 XX N HEIGHT/ALTITUDE ABOVE SEA SURFACE (metres) upwards +ve

DEPH 7 -- N SENSOR DEPTH BELOW SEA SURFACE (metres) downwards +ve

PR Pressure measurement

RT Reversing thermometer

ES Echo sounding

WL Wire length

FX Fixed (e.g. attached to tower or ship hull)

ID Standard depth for interpolated data

BT Determined from fall rate

XX Unspecified

HTSF 7 XX N HEIGHT ABOVE SEA FLOOR (metres) upwards +ve

DPSF 7 XX N DEPTH BELOW SEA FLOOR (metres) downwards +ve

LATD 7 -- N LATITUDE DEGREES (North +ve, South -ve)

-- MM - see parameter MMFX

LATM 7 -- N LATITUDE MINUTES WITHIN DEGREE (North +ve, South -ve)

-- MM - see parameter MMFX

LOND 7 -- N LONGITUDE DEGREES (East +ve, West -ve)

-- MM - see parameter MMFX

LONM 7 -- N LONGITUDE MINUTES WITHIN DEGREE (East +ve, West -ve)

-- MM - see parameter MMFX

Note: It is possible, by use of scale factors or the Fortran format, to use either one parameter (e.g. LATD) with a decimal fraction, or two parameters (e.g. LATD and LATM) with a decimal fraction in LATM or LONM. In the latter case the sign of the latitude or longitude should be attached to both degrees and minutes

PPPP K MM S

MMFX 7 XX N METHOD CODE FOR POSITION FIXING

Two character code to identify the method used for position fixing - coded as below.

(Note that this code may also be used as the method code for parameters LATD, LATM, LOND, LONM if it is appropriate to predefine the method of fixing within the definition record itself - the parameter MMFX is used as an alternative to the parameter MMMM)

CL	Celestial (star fix, sun line)
NS	Satellite Navigation
OM	Omega
LA	Loran A
RC	Loran C
EE	Decca
MD	Mid-range navigational net (approx. 200-500 km e.g. Raydist, Lorac, EPI)
SH	Short-range navigational net (less than 200 km e.g. Hi-Fix, Shoran, Autotape, Hydrodist)
AU	Acoustic (Sofar, sonar, sea floor mounted transducers etc)
BB	Radar
DR	Dead Reckoning
XX	Unspecified

FIXF 7 -- N PRIME NAVIGATION AID FIX FLAG

Flag to indicate whether the position of the measurement point was obtained directly as the result of a fix from the prime navigation aid. This parameter is used primarily with underway measurements in order to highlight the occurrence of fixes. The method code indicates the code table in use:

AA One character flag set to 'F' if position is a primary navaid position fix; otherwise left blank

The following 3 parameters describe an "error ellipse" associated with navigational fix data. Until such time as standard methods are in use, the method by which the ellipse was determined, and the confidence level associated with the ellipse, should be clearly described in plain language records accompanying the data.

EMAJ 7 XX N LENGTH OF SEMI-MAJOR AXIS OF NAVIGATION ERROR ELLIPSE (metres)

EMIN 7 XX N LENGTH OF SEMI-MINOR AXIS OF NAVIGATION ERROR ELLIPSE (metres)

EAZM 7 XX N AZIMUTH OF MAJOR AXIS OF NAVIGATION ERROR ELLIPSE
(degrees, relative to True North)
East of True North +ve

11) PPPP K MM § RELATIVE COORDINATES

ATRK 7 XX N ALONG TRACK DISPLACEMENT (metres, astern +ve)
Horizontal along track displacement of measurement point (e.g. towed sensor) behind moving platform (e.g. ship or aircraft)

XTRK 7 XX N ACROSS TRACK DISPLACEMENT (metres, starboard +ve)
Horizontal cross track (i.e. at right angles to track) displacement of measurement point from moving platform (e.g. ship or aircraft) - starboard +ve, port -ve

Note: For the following parameters the object and the reference point should be clearly identified in the plain language records accompanying the data and the geographic coordinates of one or the other should be specified.

PPPP K MM S

DIRT 7 XX N BEARING OF OBJECT FROM REFERENCE POINT (degrees True)
Direction relative to True North: east of north +ve

DIRM 7 XX N BEARING OF OBJECT FROM REFERENCE POINT (degrees Magnetic)
Direction relative to Magnetic North: east of north +ve

ELEV 7 XX N ELEVATION ANGLE OF OBJECT FROM REFERENCE POINT (degrees)
Angular elevation of the object above the horizon of the reference point

ZNTH 7 XX N ZENITH ANGLE OF OBJECT FROM REFERENCE POINT (degrees)
Zenith angle of the object as viewed from the reference point

RADD 7 XX N HORIZONTAL DISTANCE OF OBJECT FROM REFERENCE POINT (metres)

RANG 7 XX N DIRECT DISTANCE OF OBJECT FROM REFERENCE POINT (metres)
i.e. slant range in X,Y,Z coordinates

VERT 7 XX N VERTICAL DISTANCE OF OBJECT ABOVE REFERENCE POINT (metres)

DISE 7 XX N DISTANCE OF OBJECT IN DIRECTION TRUE EAST FROM REFERENCE POINT (metres) east +ve

DISN 7 XX N DISTANCE OF OBJECT IN DIRECTION TRUE NORTH FROM REFERENCE POINT (metres)
north +ve

iii) PPPP K MM S **PLATFORM MOTION/ORIENTATION**

SPDG 7 XX N TRUE PLATFORM SPEED ACROSS THE GROUND (metres/second)

SPDR 7 XX N RELATIVE PLATFORM SPEED THROUGH THE AIR/WATER (metres/second)

SPDI 7 XX N INDICATED PLATFORM SPEED (AIRCRAFT) (metres/second)

SPDV 7 XX N VERTICAL PLATFORM SPEED (metres/second) upwards +ve

HEAD 7 XX N PLATFORM HEADING (degrees, relative to True North) east +ve
Direction in which moving platform (e.g. ship or aircraft) is heading; or
orientation of a semi stationary platform (e.g. moored buoy)

PTCH 7 XX N PITCH ANGLE (degrees)

ROLL 7 XX N ROLL ANGLE (degrees)

ATCK 7 XX N ANGLE OF ATTACK (AIRCRAFT) (degrees)

SIDE 7 XX N ANGLE OF SIDESLIP (AIRCRAFT) (degrees)

TABLE 7E

PHYSICAL OCEANOGRAPHY

Parameters in this table are organised under the headings:

- i) PHYSICAL PROPERTIES
- ii) CURRENTS
- iii) OTHER PARAMETERS

i) P P P P K M M § PHYSICAL PROPERTIES

SSTP 7 -- D SEA SURFACE TEMPERATURE (degrees Celsius)

- BK Bucket/Ship intake
- PR In-situ probe
- RS Infra-red scanner
- MW Microwave scanner
- XX Unspecified

Note: Where the sea surface temperature is part of a depth series (e.g. Nansen Cast or a STD/CTD), it may also be stored in the parameter TEMP with an appropriate zero/near zero entry for pressure/depth. Similarly for sea surface salinity

TEMP 7 -- D SEA TEMPERATURE (degrees Celsius)

- RT Reversing Thermometer
- ST STD/CTD sensor
- MT Mechanical BT
- ET Expendable BT
- BT Unspecified BT
- ID Value interpolated at standard depth
- XX Unspecified

TGRD 7 -- D SEA TEMPERATURE GRADIENT (degrees Celsius/metre)

- +ve for temperature increasing downwards
- MM as for TEMP

POTM 7 -- D POTENTIAL TEMPERATURE (degrees Celsius)

- CV Computed value (method of computation to be supplied in plain language records accompanying the data)

SSAL 7 -- D SALINITY (PRE-1978 DEFN.) (parts/thousand)

- BS Bench salinometer
- PR In-situ conductivity probe
- TI Titration
- SL In-situ salinity sensor
- ID Value interpolated at standard depth
- XX Unspecified

PSAL 7 -- D PRACTICAL SALINITY (-)

- MM as for SSAL

SSSL 7 -- D SEA SURFACE SALINITY (PRE-1978 DEFN.) (parts/thousand)

- MM as for SSAL

SSPS 7 -- D SEA SURFACE PRACTICAL SALINITY (-)

- MM as for SSAL

PPPP K MM S

USAL 7 -- D UNDEFINED SALINITY (Practical Salinity or parts/thousand)
(units definition is contained in associated parameter SALD)
-- MM as for SSAL

SALD 7 -- N SALINITY UNITS FLAG
AA One character flag qualifying the salinity value stored in associated parameter
USAL - coded as follows:
P = Practical Salinity
S = Salinity (pre 1978 definition) in parts/thousand

CNDC 7 XX D ELECTRICAL CONDUCTIVITY (mhos/metre)

CHLR 7 -- D CHLORINITY (parts/thousand)
-- MM as for SSAL

CHLS 7 -- D CHLOROSITY (grams/cubic decimetre)
Expressed in grams per cubic decimetre of water at 20 deg.C (defined as
chlorinity multiplied by water density at 20 deg.C)
-- MM as for SSAL

TOTP 7 -- D TOTAL PRESSURE (decibars = 10^4 pascals): atmospheric + sea pressure
RT Reversing thermometer
PR In-situ pressure probe
XX Unspecified

REL P 7 -- D RELATIVE TOTAL PRESSURE (decibars = 10^4 pascals)
Atmospheric plus sea pressure relative to an arbitrary reference which may or
may not be specified
-- MM as for TOTP

PRES 7 -- D SEA PRESSURE (decibars = 10^4 pascals): sea surface = 0
-- MM as for TOTP

SLEV 7 XX D OBSERVED SEA LEVEL (metres)

DENS 7 -- D DENSITY (kilograms/cubic metre)
EQ International Equation (1980)
PR In-situ density probe
XX Unspecified

SVEL 7 -- D SOUND VELOCITY (metres/second)
PR In-situ sound velocity probe
CV Computed from other parameters (method of computation to be supplied in plain
language records accompanying the data)
XX Unspecified

ii) CURRENTS

Method Code for currents

The first character of the method code describes the method of averaging thus:-

MM
X- Unspecified
S- Scalar averaged
C- Vector averaged
D- Discrete value

The second character of the method code describes the type of sensor used thus:-

MM
-X Unspecified
-M Mechanical measure (e.g. rotor, impellor or vane)
-A Acoustic measure
-E Electromagnetic measure

Alternatively, if the above detail is not available or appropriate, the method code may be entered as follows:-

MM
EL Eulerian measure - method unspecified
LG Lagrangian measure - method unspecified

PPPP K MM S

HCSP 7 -- D HORIZONTAL CURRENT SPEED (metres/second)
-- MM as above

HCDT 7 -- D DIRECTION TO WHICH HORIZONTAL CURRENT IS FLOWING (degrees relative to True North)
-- MM as above

HCDM 7 -- D DIRECTION TO WHICH HORIZONTAL CURRENT IS FLOWING (degrees relative to Mag. North)
-- MM as above

EWCT 7 -- D EAST (TRUE) COMPONENT OF CURRENT (metres/second): eastwards flowing +ve
-- MM as above

NSCT 7 -- D NORTH (TRUE) COMPONENT OF CURRENT (metres/second): northwards flowing +ve
-- MM as above

EWCM 7 -- D EAST (MAGNETIC) COMPONENT OF CURRENT (metres/second): eastwards flowing +ve
-- MM as above

NSCM 7 -- D NORTH (MAGNETIC) COMPONENT OF CURRENT (metres/second): northwards flowing +ve
-- MM as above

SCSP 7 -- D SEA SURFACE CURRENT SPEED (metres/second)
-- MM as above

SCDT 7 -- D DIRECTION TO WHICH SEA SURFACE CURRENT IS FLOWING
(degrees, relative to True North)
-- MM as above

iii) P P P P K M M \$ OTHER PARAMETERS

SECC 7 XX D SECCHI DISC DEPTH (metres)

WCLR 7 XX D WATER COLOUR (FOREL-ULE SCALE)

Two character code to indicate the colour of the water

ICEF 7 -- N FLAG FOR ICE IN VICINITY OF HYDROGRAPHIC OBSERVATIONS

AA One character code to indicate the occurrence of ice within the vicinity of a hydrographic station. Coded according to the ICES system as follows:

- 0 No ice
- 1 Ice present in vicinity but not identified as to type or amount
- 2 Few bergs (10 or less)
- 3 Many bergs (more than 10)
- 4 Pack ice more than 1 nautical mile from station; coverage 6/10 or less
- 5 Pack ice more than 1 nautical mile from station; coverage more than 6/10
- 6 Pack ice less than 1 nautical mile from station; coverage 6/10 or less
- 7 Pack ice less than 1 nautical mile from station; coverage more than 6/10
- 8 Station actually within heavy concentration of ice e.g. observations from ice islands, drifting pack, beset vessels, fast ice
- 9 No observations of ice made

CAST 7 -- N HYDROGRAPHIC CAST TYPE

AA Three character code used when different types of hydrographic depth series are merged in the same file and the need exists to identify the different methods of data collection; coded as follows:-

WBR	classical hydrographic station e.g. water bottles with reversing thermometers	UBT	unspecified BT
ROS	rosette sampler with CTD	BTH	BATHY message
CTD	CTD cast	TSC	TESAC message
STD	STD cast	DRB	DRIBU drifting buoy message
MBT	mechanical BT	OTH	other method
XBT	expendable BT	XXX	unspecified or unknown

LVLS 7 -- N SELECTION OF DEPTH LEVELS

AA Two character code to specify the method by which depth levels are sampled/digitized in a depth series; coded as follows:-

- DI Data selected at constant depth intervals from continuous profile
- IF Data selected at inflexion points from continuous profile
- FX Data selected at predefined fixed levels, e.g. standard depths, from continuous profile
- CB Data selected from continuous profile using combination of above criteria
- OB Observed levels only (original measurements at discrete depths rather than in continuous profile)
- ST Data interpolated to standard depth levels from observed levels
- MX Observed levels plus depth interpolations to standard levels
- XX Method unspecified

TDFL 7 -- D TRACE DIRECTION FLAG

AA One character flag to indicate data collection mode at hydrographic station - coded as follows:

- X - not applicable or unspecified
- D - data collected serially during descent of probe
- A - data collected serially during ascend of probe

PPPP K MM S

PRHB 7 -- N PROBE HIT BOTTOM INDICATOR

AA One character flag to indicate whether depth profiling data was terminated by probe hitting the sea floor - coded as follows:-

Code

0 unspecified

1 probe hit sea floor

DROP 7 XX D DEPTH OF DROGUE (metres)

Used particularly with drifting buoy data

TABLE 7F

WAVES

Introduction

This section contains the most commonly measured wave parameters and includes a precise definition of each. Where the user's parameter does not accord with these definitions, the user is encouraged to define his own parameter code together with its definition, as described at the beginning of Table 7.

A crest is an event where the water surface has zero slope, is preceded by a positive slope and followed by a negative slope. A trough is an event where the water has zero slope, is preceded by a negative slope and followed by a positive slope.

The interpretation of many of the parameters in this section is dependent on the record length i.e. the period of time over which the passage of waves is observed, and in such cases this period should also be stored with the data e.g. as parameter DRSC7PRN (see Table 7C).

The definition of mean record level which is of importance in the zero crossing type of analysis, is not concise when significant variation in water surface elevation is caused by the tide within the duration of the record. Floating buoys tend to filter out this long period movement whereas staff gauges do not. A "zero crossing" is to be understood as the crossing of the mean record level by the water surface at that instant (after filtering tide effects).

The zero crossing crest (trough) amplitude is the maximum vertical distance between the mean record level and the maximum (minimum) level that occurred between an upward (downward) and a following downward (upward) going zero crossing. Both quantities are always positive.

Method Code

Unless defined otherwise, the first character of the method code describes the method for calculating the parameter as follows:-

<u>MM</u>	
X-	unspecified
F-	Fourier Transform (and Integration where appropriate)
L-	Lag correlation analysis
C-	Simple computer analysis of record
M-	Manual analysis of chart record
E-	Visual estimation

The second character describes the sensor used thus:-

<u>MM</u>	
-X	unspecified
-U	Unspecified - instrumental measurement
-A	Accelerometer buoy
-B	Shipborne wave recorder
-E	Inverted echo-sounder
-L	Laser altimeter
-P	Bottom mounted pressure device
-R	Satellite altimeter
-S	Staff gauge
-V	Visual

The parameters in this table are organised under the following headings:

- i) ESTIMATES OF WAVE HEIGHT, PERIOD AND DIRECTION
- ii) WAVE HEIGHT
- iii) WAVE PERIOD
- iv) INSTANTANEOUS SURFACE MEASUREMENTS
- v) WAVE SPECTRA
- vi) DIRECTIONAL WAVE SPECTRA

i) **PPPP K MM § ESTIMATES OF WAVE HEIGHT, PERIOD AND DIRECTION**

This section covers parameters based on simple estimates of wave conditions either by visual observation (MM = 'EV') or by visual estimation with instrumental aid (MM = 'EU')

SEAS 7 XX D SEA STATE (WMO CODE 3700)

One character code describing wave roughness - coded as in WMO Code Table 3700 - see Annex X

VEST 7 -- D VISUAL AVERAGE WAVE HEIGHT (metres) : H_v

Significant wave height as estimated by visual means

VPER 7 -- D VISUAL ESTIMATE OF WAVE PERIOD (seconds)

Visual estimate of the period between successive waves

VDIR 7 -- D VISUAL ESTIMATE OF DIRECTION FROM WHICH WAVES ARE COMING

(degrees, relative to True North)

Visual estimate of the direction from which the dominant waves are coming - east of True North +ve

SWDR 7 -- D DIRECTION FROM WHICH SWELL IS COMING (degrees, relative to True North)

East of True North +ve

SWHT 7 -- D SWELL HEIGHT (metres)

Height of dominant swell above still water level

SWPR 7 -- D SWELL PERIOD (seconds)

Period between successive swell maxima

ii) **PPPP K MM § WAVE HEIGHT**

WMDP 7 -- D MEAN WATER DEPTH (metres) : Z_1

Vertical distance between mean water level (i.e. average water surface over a period of at least one year) and the sea floor - always positive

WSDP 7 -- D STILL WATER DEPTH (metres) : Z_2

Vertical distance between still water level (i.e. level of water surface in the absence of wave activity) and the sea floor - always positive

WRDP 7 -- D MEAN RECORD WATER DEPTH (metres) : Z_3

Vertical distance between mean record level (average water surface over the period of observation e.g. 20 minutes) and the sea floor - always positive

VMXL 7 -- D MAXIMUM WAVE LEVEL (metres) : Y_1

Maximum zero crossing crest amplitude observed in a record - always positive (= maximum crest amplitude)

- VMNL 7 -- D MINIMUM WAVE LEVEL (metres) : Y_z
Maximum zero crossing trough amplitude observed in a record - always positive
(= maximum trough amplitude)
- VTKC 7 -- D SECOND HIGHEST WAVE CREST (metres)
Second highest crest amplitude observed in a record - always positive
- VTKD 7 -- D SECOND LOWEST WAVE TROUGH (metres)
Second highest trough amplitude observed in a record - always positive
- VMCX 7 -- D MAXIMUM CREST TO TROUGH WAVE HEIGHT (metres) : $H_{c,max}$
Maximum H_c as observed in a specified period of time, which should always be stated, where H_c is the vertical distance between a crest and the immediately preceding (or following) trough. Within a given data set H_c should refer consistently to either preceding or following troughs but not to both - the convention used should be stated clearly
- VZMX 7 -- D MAXIMUM ZERO CROSSING WAVE HEIGHT (metres) : $H_{z,max}$
Maximum H_z as observed in a specified period of time, which should always be stated, where H_z is the sum of the zero crossing crest amplitude and the immediately preceding (or following) zero crossing trough amplitude (both quantities being positive). Within a given data set H_z should refer consistently to either preceding or following zero crossing troughs but not to both - the convention used should be stated clearly
- VAVH 7 -- D AVERAGE HEIGHT HIGHEST ONE THIRD WAVES (metres) : $H_{z,1/3}$
Average of the highest one third of the zero up-crossing (or down-crossing according to convention used) wave heights for a stated period of time
- VTDH 7 -- D TUCKER DRAPER SIGNIFICANT WAVE HEIGHT (metres)
Significant wave height as estimated by the Tucker Draper method (Draper.L. Proc. Instn. Civ. Engrs. 26, 291-304 (1963) for a stated period of time
- VRMS 7 -- D RMS WAVE DISPLACEMENT (metres) : H_{RMS}
Square root of the variance, i.e. the square root of the average square displacement of the water surface from the mean record level
- VCAR 7 -- D CHARACTERISTIC WAVE HEIGHT (metres) : H_{ms}
Wave height parameter as computed from the RMS value of the record i.e. $4H_{RMS}$ for a stated period of time

iii) **PPPP K MM § WAVE PERIOD**

- VTZM 7 -- D PERIOD OF MAXIMUM ZERO CROSSING WAVE (seconds) : $T_{Hz,max}$
Interval between the two upward (or downward according to the convention adopted for VZMX) zero crossings defining the maximum zero crossing wave height wave
- VTZA 7 -- D AVERAGE ZERO CROSSING WAVE PERIOD (seconds) : \bar{T}_z
Average of the zero crossing intervals as obtained by dividing the record duration by the number of times the water elevation crosses the mean record level in one direction
- VTCA 7 - D AVERAGE WAVE CREST PERIOD (seconds) : \bar{T}_c
Time obtained by dividing the record duration by the total number of crests in the record

VBRF 7 -- D WAVES SPECTRAL WIDTH (BROADNESS)
Defined as equal to $(1 - (\bar{T}_c/\bar{T}_z)^2)^{1/2}$

iv) **PPPP K MM § INSTANTANEOUS SURFACE MEASUREMENTS**

VWSE 7 -- D INSTANTANEOUS WATER SURFACE ELEVATION (metres)
Instantaneous water surface elevation relative to some arbitrary mean - positive upwards
Processing carried out on data:
X- unspecified
F- digital filter has been used
A- analogue filter has been used
(Second character of MM as for other wave parameters i.e. sensor type)

VWSA 7 -- D INSTANTANEOUS HEAVE ACCELERATION (metres/second²)
-- MM as for VWSE

VWTE 7 -- D WATER SURFACE EAST-WEST TILT ANGLE (degrees)
Instantaneous water surface tilt in the east-west (true) vertical plane
- measured relative to the horizontal, east upwards positive
-- MM as for VWSE

VWTN 7 -- D WATER SURFACE NORTH-SOUTH TILT ANGLE (degrees)
Instantaneous water surface tilt in the north-south (true) vertical plane
- measured relative to the horizontal, north upwards positive
-- MM as for VWSE

v) **PPPP K MM § WAVE SPECTRA**

VSDN 7 -- D WAVE VARIANCE SPECTRAL DENSITY (metres²/hertz) : S(f)
Estimate of the spectral density of the variance of the water surface elevation at a specified frequency (as specified in associated parameter SPCF7XXN - see Table 7C)

VTPK 7 -- D WAVE SPECTRUM PEAK PERIOD (seconds) : T_p
Inverse of the frequency at which the maximum variance spectral density occurs

MOMENTS OF THE VARIANCE SPECTRAL DENSITY

The n'th moment m_n of the variance spectral density function is defined as the integral of fⁿS(f)df (limits of integration being defined in parameters LOWF7XXN and HIGF7XXN - see Table 7C):

VMTA 7 -- D ZEROETH MOMENT OF WAVE SPECTRUM (metres²) : m₀

VMTB 7 -- D FIRST MOMENT OF WAVE SPECTRUM (metres².hertz) : m₁

VMTC 7 -- D SECOND MOMENT OF WAVE SPECTRUM (metres².hertz²) : m₂

VMTD 7 -- D THIRD MOMENT OF WAVE SPECTRUM (metres².hertz³) : m₃

VMTE 7 -- D FOURTH MOMENT OF WAVE SPECTRUM (metres².hertz⁴) : m₄

VMTM 7 -- D FIRST NEGATIVE MOMENT OF WAVE SPECTRUM (metres²/hertz) : m₋₁

VMTN 7 -- D SECOND NEGATIVE MOMENT OF WAVE SPECTRUM (metres²/hertz²) : m₋₂

PPPP K MM S

VSWD 7 -- D WAVES SPECTRAL WIDTH FROM MOMENTS

Spectral width from moments of the spectrum defined as equal to

$$\frac{(m_0 \cdot m_4 - m_2^2)^{1/2}}{(m_0 \cdot m_4)^{1/2}}$$

VSMA 7 -- D SPECTRAL MOMENTS (-1,0) WAVE PERIOD (seconds) : $T_{m_{-1,0}}$

Where $T_{m_{-1,0}} = m_{-1}/m_0$

VSMB 7 -- D SPECTRAL MOMENTS (0,1) WAVE PERIOD (seconds) : $T_{m_{0,1}}$

Where $T_{m_{0,1}} = m_0/m_1$

VSMC 7 -- D SPECTRAL MOMENTS (0,2) WAVE PERIOD (seconds) : $T_{m_{0,2}}$

Where $T_{m_{0,2}} = (m_0/m_2)^{1/2}$

(sometimes referred to as average apparent period)

VSMD 7 -- D SPECTRAL MOMENTS (2,4) WAVE PERIOD (seconds) : $T_{m_{2,4}}$

Where $T_{m_{2,4}} = (m_2/m_4)^{1/2}$

vi) PPPP K MM § DIRECTIONAL WAVE SPECTRA

The following eight parameters represent the spectral components estimated at a specified frequency, f (as specified in associated parameter SPCF7XXN - see Table 7C), from the cross spectral analysis of instantaneous measurements of heave, east-west tilt and north-south tilt. The following conventions are adopted:

heave - water surface elevation in metres relative to an arbitrary mean, positive upwards

east-west tilt - water surface tilt in degrees in the east-west (true) vertical plane; measured relative to the horizontal, east upwards positive

north-south tilt - water surface tilt in degrees in the north-south (true) vertical plane; measured relative to the horizontal, north upwards positive

Note that the auto-spectrum of heave ($C_{11}(f)$) is given by parameter VSDN 7 -- D in the previous section

VCXX 7 -- D AUTO-SPECTRUM OF NORTH-SOUTH TILT (degrees²/hertz): $C_{22}(f)$

VCYY 7 -- D AUTO-SPECTRUM OF EAST-WEST TILT (degrees²/hertz): $C_{33}(f)$

VQZX 7 -- D QUAD-SPECTRUM OF HEAVE AND NORTH-SOUTH TILT (metre.degrees/hertz): $Q_{12}(f)$

VQZY 7 -- D QUAD-SPECTRUM OF HEAVE AND EAST-WEST TILT (metre.degrees/hertz): $Q_{13}(f)$

VQXY 7 -- D QUAD-SPECTRUM OF NORTH-SOUTH AND EAST-WEST TILTS (degrees²/hertz): $Q_{23}(f)$

VCZX 7 -- D CO-SPECTRUM OF HEAVE AND NORTH-SOUTH TILT (metre.degrees/hertz): $C_{12}(f)$

VCZY 7 -- D CO-SPECTRUM OF HEAVE AND EAST-WEST TILT (metre.degrees/hertz): $C_{13}(f)$

VCXY 7 -- D CO-SPECTRUM OF NORTH-SOUTH AND EAST-WEST TILTS (degrees²/hertz): $C_{23}(f)$

The following three parameters may be derived from the above cross spectral components (see e.g. Longuet-Higgins et al (1963), 'Observations of the directional spectrum of sea waves using the motions of a floating buoy' in Ocean Wave Spectra, pp 111-132, Prentice-Hall, Englewood Cliffs):

PPPP K MM S

VNUM 7 -- D WAVE NUMBER FROM CROSS SPECTRA (degrees/metre): $k(f)$
where $k(f) = \text{sq.rt.} ((C_{22}+C_{33})/C_{11})$

VMWD 7 -- D MEAN WAVE DIRECTION FROM CROSS SPECTRA (degrees): $\theta_1(f)$
where $\theta_1(f) = \text{arc tan} (Q_{13}/Q_{12})$
gives the mean direction, relative to true North, from which the waves are coming (on the assumption that the directional distribution is unimodal) and is based on the first angular harmonics of the directional spectrum at the specified frequency

VSPR 7 -- D WAVE DIRECTIONAL SPREAD FROM CROSS SPECTRA (degrees): $\theta_2(f)$
where $\theta_2(f) = \text{sq.rt.} (2-2C)$
in which $C = \text{sq.rt.} ((Q_{12}^2+Q_{13}^2)/(C_{11}(C_{22}+C_{33})))$
For a narrow directional distribution, $\theta_2(f)$ gives the rms spread about the mean wave direction and is based on the first order angular harmonics of the directional spectrum

VSDS 7 -- D DIRECTIONAL WAVE SPECTRUM DENSITY (metres²/hertz): $S(f,\theta)$
Spectral density of the variance of the water surface elevation at a specified frequency, f , due to waves coming from a specified direction, θ , within a band of width, $\Delta\theta$, where
 f is specified in associated parameter SPCF (see Table 7C)
 θ is specified in associated parameter VDEP (see below)
 $\Delta\theta$ is specified in associated parameter BDIR (see below)

VDEP 7 XX N SPECIFIED DIRECTION OF WAVE ENERGY PROPAGATION (degrees)
Used for identifying a specific directional component of a directional wave spectrum. Expressed relative to true North in the direction from which the waves are coming

BDIR 7 XX N BANDWIDTH OF DIRECTIONAL ANALYSIS (degrees)
Directional bandwidth of directional spectrum analysis

VPED 7 -- D WAVE SPECTRUM PEAK ENERGY DIRECTION (degrees)
Direction of wave propagation at the frequency of the maximum variance density. Measured relative to true North in the direction from which waves are coming

VMED 7 -- D WAVE SPECTRUM MEAN ENERGY DIRECTION (degrees)
Within each frequency band a vector is defined having the magnitude of the wave energy within the band and the direction of the peak energy of the waves in the band. The mean energy direction is the direction of the resultant of the sum of these vectors over all frequency bands

TABLE 7G

METEOROLOGY

Parameters in this table are organised under the headings:

- i) CLOUD, WEATHER, VISIBILITY AND RAIN
- ii) PRESSURE AND HUMIDITY
- iii) WIND
- iv) TEMPERATURE
- v) RADIATION
- vi) FLUCTUATIONS IN WIND SPEED, TEMPERATURE AND HUMIDITY

i) **PPPP K MM \$ CLOUD, WEATHER, VISIBILITY AND RAIN**

CCVR 7 XX A TOTAL CLOUD COVER IN TENTHS OF SKY (tenths)

CLDA 7 XX A TOTAL CLOUD AMOUNT (OKTAS-WMO CODE 2700)

One character code for total cloud cover in oktas of sky - coded as in WMO Code Table 2700 - see Annex X (note: set as blank if not estimated, set to '9' if sky obscured or cloud amount cannot be estimated)

CLCM 7 XX A AMOUNT OF LOW/MEDIUM ALTITUDE CLOUD (OKTAS - WMO CODE 2700)

One character code for the amount of all low level cloud (C_L) present or, if no C_L cloud is present, the amount of all the medium level cloud (C_M) present - coded as in WMO Code Table 2700 - see Annex X

CLDB 7 XX A CLOUD BASE ALTITUDE (metres)

Height above ground or sea surface

CLDH 7 XX A CLOUD BASE HEIGHT (WMO CODE 1600)

One character code for the height above ground or sea surface of the base of the lowest cloud seen - coded as in WMO Code Table 1600 - see Annex X

CLDT 7 XX A CLOUD TYPE (WMO CODE 0500)

One character code for the genus of the dominant cloud type - coded as in WMO Code Table 0500 - see Annex X

CLCL 7 XX A TYPE OF LOW ALTITUDE CLOUD (WMO CODE 0513)

One character code to describe the clouds of genera Stratocumulus, Stratus, Cumulus and Cumulonimbus - coded as in WMO Code Table 0513 - see Annex X

CMCM 7 XX A TYPE OF MEDIUM ALTITUDE CLOUD (WMO CODE 0515)

One character code to describe the clouds of genera Altopcumulus, Altostratus and Nimbostratus - coded as in WMO Code Table 0515 - see Annex X

CHCH 7 XX A TYPE OF HIGH ALTITUDE CLOUD (WMO CODE 0509)

One character code to describe the clouds of genera Cirrus, Cirrocumulus and Cirrostratus - coded as in WMO Code Table 0509 - see Annex X

WWCD 7 XX A PRESENT WEATHER (WMO CODE 4677)

Two character code to describe the present weather - coded as in WMO Code Table 4677 - see Annex X

WTHA 7 XX A PAST WEATHER (WMO CODE 4561)
 One character code to describe recent/past weather - coded as in WMO Code Table
 4561 - see Annex X

VISB 7 XX A HORIZONTAL VISIBILITY (metres)

PRTN 7 XX A PRECIPITATION AMOUNT (millimetres)
 Rainfall amount in a specified period (specified in associated parameter
 DRHR7PRN - see Table 7C)

PRRT 7 XX A PRECIPITATION RATE (millimetres/hour)

ii) **PPPP K MM S PRESSURE AND HUMIDITY**

ATMS 7 XX A ATMOSPHERIC PRESSURE AT SEA LEVEL (hectopascals = millibars)
 Note: either measured at sea level or reduced to mean sea level

ATMP 7 XX A ATMOSPHERIC PRESSURE AT ALTITUDE (hectopascals)

ATPT 7 XX A ATMOSPHERIC PRESSURE TENDENCY (hectopascals/hour)
 (rising +ve, falling -ve)

VAPP 7 XX A ACTUAL WATER VAPOUR PRESSURE (hectopascals)

ABSH 7 XX A ABSOLUTE HUMIDITY (grams/cubic metre)

SPEH 7 XX A SPECIFIC HUMIDITY (grams/kilogram)

RELH 7 XX A RELATIVE HUMIDITY (percent)

HMXR 7 XX A HUMIDITY MIXING RATIO (grams/kilogram)
 also called mass mixing ratio

LWCT 7 XX A LIQUID WATER CONTENT (grams/cubic metre)

TWCT 7 XX A TOTAL WATER CONTENT (grams/cubic metre)

iii) **PPPP K MM S WIND**

WSPD 7 XX A HORIZONTAL WIND SPEED (metres/second)

WDIR 7 XX A DIRECTION FROM WHICH WIND IS BLOWING (degrees relative to True North)

GSPD 7 XX A GUST WIND SPEED (metres/second)

GDIR 7 XX A DIRECTION FROM WHICH GUST WIND IS BLOWING (degrees relative to True North)

WFBS 7 XX A WIND FORCE ON BEAUFORT SCALE
 Two digit Beaufort Scale - see e.g. Manual on Codes (WMO - No. 306)

WSPE 7 XX A EASTWARD (TRUE) COMPONENT OF WIND SPEED (metres/second): U
 (+ve towards east)

WSPN 7 XX A NORTHWARD (TRUE) COMPONENT OF WIND SPEED (metres/second): V
(+ve towards north)

VWSH 7 XX A VERTICAL WIND SHEAR (metres/second per kilometre)
Vertical gradient of the horizontal wind speed - positive for wind speed
increasing upwards

WVER 7 XX A VERTICAL WIND SPEED (metres/second)
(+ve upwards)

iv) **PPPP K MM § TEMPERATURE**

DRYT 7 XX A DRY BULB TEMPERATURE (degrees Celsius)

WETT 7 XX A WET BULB TEMPERATURE (degrees Celsius)

DEWT 7 XX A DEW POINT TEMPERATURE (degrees Celsius)

DEWD 7 XX A DEW POINT DEPRESSION (degrees Celsius)

SOLT 7 XX G GROUND (SOIL) TEMPERATURE (degrees Celsius)

STAG 7 XX A STAGNATION TEMPERATURE (degrees Celsius)

VIRT 7 XX A VIRTUAL AIR TEMPERATURE (degrees Celsius)

POTT 7 XX A POTENTIAL AIR TEMPERATURE (degrees Celsius)

BRIT 7 XX A BRIGHTNESS (RADIATIVE) TEMPERATURE (degrees Celsius)

DTDZ 7 -- A VERTICAL AIR TEMPERATURE GRADIENT (degrees Celsius/metre)
Negative for temperature decreasing upwards - parameter is qualified by the
entry in MM thus

DB	Dry bulb temperature
EP	Dew point temperature
WB	Wet bulb temperature
VT	Virtual temperature
PT	Potential temperature

TDIF 7 -- A AIR TEMPERATURE DIFFERENCE BETWEEN TWO LEVELS (UPPER-LOWER) (degrees Celsius)
Parameter is qualified by the entry in MM thus:
-- MM as for DTDZ

ASTD 7 XX B AIR-SEA TEMPERATURE DIFFERENCE (degrees Celsius)
Dry bulb temperature minus sea surface temperature

v) **PPPP K MM § RADIATION**

SDIR 7 XX A SHORT-WAVE DIRECT RADIATION (watts/square metre)

SDIF 7 XX A SHORT-WAVE DIFFUSE RADIATION (watts/square metre)

SINC 7 XX A SHORT-WAVE INCOMING RADIATION (watts/square metre)

SOUT 7 XX A SHORT-WAVE OUTGOING RADIATION (watts/square metre)
 LINC 7 XX A LONG-WAVE INCOMING RADIATION (watts/square metre)
 LOUT 7 XX A LONG-WAVE OUTGOING RADIATION (watts/square metre)
 NETR 7 XX A NET RADIATION (watts/square metre)
 ULTR 7 XX A ULTRA-VIOLET RADIATION (watts/square metre)
 NIRR 7 XX A NEAR-INFRARED RADIATION (watts/square metre)
 QSOL 7 XX G GROUND HEAT FLUX (watts/square metre)

vi) P P P P K M M § FLUCTUATIONS IN WIND SPEED, TEMPERATURE AND HUMIDITY

SDWS 7 -- A STANDARD DEVIATION OF WIND SPEED (metres/second)

Parameter is qualified by the entry in MM thus:

HH Horizontal wind speed
 UU Eastwards component of wind speed
 VV Northwards component of wind speed
 WW Vertical wind speed

VRWS 7 -- A VARIANCE OF WIND SPEED (metres/second)²

Parameter is qualified by the entry in MM

-- MM as for SDWS

SDAT 7 -- A STANDARD DEVIATION OF AIR TEMPERATURE (degrees Celsius)

Parameter is qualified by the entry in MM thus:

DB Dry bulb temperature
 RT Virtual temperature
 PT Potential temperature

VRAT 7 -- A VARIANCE OF AIR TEMPERATURE (degrees Celsius)²

Parameter is qualified by the entry in MM

-- MM as for SDAT

SDHU 7 XX A STANDARD DEVIATION OF SPECIFIC HUMIDITY (grams/kilogram)

VRHU 7 XX A VARIANCE OF SPECIFIC HUMIDITY (grams/kilogram)²

CVWS 7 -- A CO-VARIANCE OF WIND SPEED COMPONENTS (metres/second)²

Co-variance of the fluctuations of wind speed components around their mean values. The components are identified by the entry in MM thus:

UV Co-variance of components U and V
 UW Co-variance of components U and W
 VW Co-variance of components V and W

where U = eastward component of wind speed (+ve towards east)
 V = northward component of wind speed (+ve towards north)
 W = vertical component of wind speed (+ve upwards)

PPPP K MM S

CVWT 7 -- A CO-VARIANCE OF WIND SPEED AND AIR TEMPERATURE (degC.m/s)
Co-variance of the fluctuations of wind speed component and air temperature around their mean values. The wind speed component and temperature measurement are identified by the entry in MM.

1st character of MM specifies the wind speed component thus:

- H- horizontal component of wind speed
- U- eastward component of wind speed (+ve towards east)
- V- northward component of wind speed (+ve towards north)
- W- vertical component of wind speed (+ve upwards)

2nd character of MM qualifies the temperature thus:

- D dry bulb temperature
- R virtual temperature
- P potential temperature

CVWQ 7 -- A CO-VARIANCE OF WIND SPEED AND SPECIFIC HUMIDITY (m/s).g/kg
Co-variance of the fluctuations of wind speed component and specific humidity around their mean values. The wind speed component is identified by the entry in MM thus:

- Q 1st character of MM specifies the wind speed component and is coded as for 1st character of MM in parameter CVWT

CVTQ 7 -- A CO-VARIANCE OF AIR TEMPERATURE AND SPECIFIC HUMIDITY (degC.g/kg)
Co-variance of the fluctuations of air temperature and specific humidity around their mean values. The temperature measurement is identified by the entry in MM thus:

- DQ co-variance of dry bulb temperature and specific humidity
- RQ co-variance of virtual temperature and specific humidity
- PQ co-variance of potential temperature and specific humidity

TABLE 7H

GEOPHYSICS

Parameters for Bathymetry, Magnetics and Gravity

PPPP K MM §

TWTT 7 XX N BATHYMETRIC TWO WAY TRAVEL TIME (seconds)
Two way echo-sounding travel time corrected for transducer depth and other such factors (e.g. motor speed) as are defined in the documentation accompanying the data

BATH 7 -- N BATHYMETRIC DEPTH (metres)
Echo-sounding depth corrected for transducer depth. The first character of the method code defines whether the depth has been corrected for the varying speed of sound in seawater viz:-

- C- Corrected depth
- U- Uncorrected depth (see below for assumed sound velocity)
- R- Corrected depth including corrections for refraction effects (non vertical beams only)

The second character defines the correction procedure:

- T "Echo-sounding correction tables", 3rd edition N.P.139 (UK)
- M Matthews Tables N.P.139 (UK), 2nd edition
- V Velocimeter dips
- W W.D. Wilson (1960) formula on T-S data
- K S. Kuwahara formula on T-S data
- G V.A. Del Grosso (1972) formula on T-S data
- Z Other (described in documentation accompanying the data)

UA Uncorrected depth; assumed sound velocity = 1500 metres/second

UF Uncorrected depth; assumed sound velocity = 800 fathoms/second (= 1463 metres/second)

UZ Uncorrected depth; assumed sound velocity = value other than 1463 or 1500 metres/second (value specified in plain language documentation)

DATM 7 -- N BATHYMETRIC DATUM

Code to identify the common datum to which bathymetric depth values have been corrected - this correction should not be confused with corrections for transducer depth or for the varying speed of sound in sea water.

The code table in use is defined by the method code viz:

AA MGD77 Bathymetric Datum Code (US National Geophysical Data Centre) with the following code values:

- 00 - No correction applied (sea level)
- 01 - Lowest normal low water
- 02 - Mean lower low water
- 03 - Lowest low water
- 04 - Mean lower low water spring
- 05 - Indian spring low water
- 06 - Mean low water spring
- 07 - Mean sea level
- 08 - Mean low water
- 09 - Equatorial spring low water
- 10 - Tropic lower low water
- 11 - Lowest astronomical tide
- 88 - Other, specified in documentation accompanying data

PPPP K MM S

SVCZ 7 XX N BATHYMETRY SOUND VELOCITY CORRECTION AREA

Identifier of the correction table used to correct bathymetric depths for the varying speed of sound in sea water. Thus with bathymetric depth parameter BATH7CTN it refers to the correction area number from the Third Edition Tables; for BATH7CMN the Matthews Area number

MAGT 7 XX N TOTAL MAGNETIC FIELD (nanoteslas = gammas)

MAGR 7 -- N RESIDUAL MAGNETIC FIELD (nanoteslas = gammas)

Residual Field = Total Field - Reference Field

The reference field is identified by the method code thus:

AA IGRF 1965

AB IGRF 1975

AC IGRF 1980

DA DGRF 1965

DB DGRF 1970

DC DGRF 1975

PA PGRF 1975

XX Other reference field (described in documentation accompanying the data)

MAGC 7 XX N MAGNETIC FIELD CORRECTION (nanoteslas = gammas)

Correction applied to magnetic field measurement to compensate for diurnal, storm or other effects as described in the data documentation

GRAV 7 XX N OBSERVED GRAVITY (milligals)

Observed gravity corrected for Eotvos, drift, bias and tares

GFAA 7 -- N GRAVITY FREE-AIR ANOMALY (milligals)

Free-air Anomaly = Observed Gravity - Theoretical Gravity

The theoretical gravity formula used is identified by the first character of the method code viz:

A- Heiskanen 1924 = $978.052 (1 + 0.005285 \sin^2 (\text{lat}) - 0.0000070 \sin^2 (2*\text{lat}) +$

$0.000027 \cos^2 (\text{lat}) \cos^2 (\text{long} - 18^\circ))$

B- International 1930 = $978.0490 (1 + 0.0052884 \sin^2 (\text{lat}) - 0.0000059 \sin^2 (2*\text{lat}))$

C- IAG System 1967 = $978.03185 (1 + 0.005278895 \sin^2 (\text{lat}) + 0.000023462 \sin^4 (\text{lat}))$

Z- Other (described in documentation accompanying the data)

The reference system is specified in the second character of the method code viz:

-A System IGSN 1971

-P Potsdam system

-L Local system (described in documentation accompanying the data)

-Z Other system (described in documentation accompanying the data)

GBGA 7 XX N GRAVITY BOUGER ANOMALY (milligals)

GEOT 7 -- N GRAVITY EOTVOS CORRECTION (milligals)

AA Eotvos correction = $7.5 V \cos (\text{latitude}) \sin (\text{heading}) + 0.0042 V^2$
(note in documentation accompanying the data if V^2 not used)

TABLE 71
CHEMISTRY

PPPP K MM S

CNQF 7 -- N CHEMICAL CONTENT QUALIFIER FLAG

Used to qualify a recorded value of chemical concentration in cases where the only indication of the concentration is that it is 'less than' or 'greater than' the recorded value.

AA One character flag set to:

- 'L' if the concentration is less than the recorded value
- 'G' if the concentration is greater than the recorded value
- 'T' if trace indicated but no measurement attempted
- otherwise the character is blank filled

This parameter is normally included immediately prior to the chemical concentration parameter to which it relates. To avoid ambiguity it is recommended that, in the definition line image defining CNQF, the secondary parameter should reference the chemical parameter to which it applies.

PHPH 7 XX D HYDROGEN ION CONCENTRATION (pH)

ALKY 7 XX D TOTAL ALKALINITY (micromoles/cubic decimetre)

Micromoles of hydrogen ions to neutralise the weak bases in one cubic decimetre of sea water at 20 deg.C
(Note: 1 milliequivalent/dm³ = 1000 micromoles/dm³)

CALK 7 XX D CARBONATE ALKALINITY (micromoles/cubic decimetre)

Micromoles of hydrogen ions to neutralise the weak bases (carbonate and bicarbonate only) in one cubic decimetre of sea water at 20 deg.C

CPHL 7 XX D CHLOROPHYLL-a CONTENT (micrograms/cubic decimetre)

Micrograms of chlorophyll-a per cubic decimetre of water at 20 deg.C

DOXY 7 -- D DISSOLVED OXYGEN (micromoles/cubic decimetre)

Micromoles of dissolved oxygen per cubic decimetre of water at 20°C.
(Note: to convert from measurements in millilitres per litre multiply by 44.66 - the scaling factor in columns 49-56 of the definition record may be used to affect this conversion)

PR In-situ oxygen probe

TI Titration

XX Unspecified

For the following parameters the method code MM is used to qualify the type of measurement made thus:

DX Dissolved component only i.e. after passing water through filter

PX Particulate component only

TX Dissolved + particulate components

XX Component unspecified or unknown

PHOS 7 -- D PHOSPHATE (PO₄-P) CONTENT (micromoles/cubic decimetre)

Micromoles of phosphate phosphorus per cubic decimetre of water at 20 deg.C

-- MM see above

TPHS 7 -- D TOTAL PHOSPHORUS (P) CONTENT (micromoles/cubic decimetre)

Micromoles of total phosphorus per cubic decimetre of water at 20 deg.C

-- MM see above

PPPP K MM S

NTRA 7 -- D NITRATE (NO₃-N) CONTENT (micromoles/cubic decimetre)
Micromoles of nitrate nitrogen per cubic decimetre of water at 20 deg.C
-- MM see above

NTRI 7 -- D NITRITE (NO₂-N) CONTENT (micromoles/cubic decimetre)
Micromoles of nitrite nitrogen per cubic decimetre of water at 20 deg.C
-- MM see above

NTRZ 7 -- D NITRATE + NITRITE CONTENT (micromoles/cubic decimetre)
Sum of micromoles of nitrate nitrogen and nitrite nitrogen per cubic decimetre
of water at 20 deg.C
-- MM see above

NTOT 7 -- D TOTAL NITROGEN (N) CONTENT (micromoles/cubic decimetre)
Micromoles of total nitrogen per cubic decimetre of water at 20 deg.C
-- MM see above

NORG 7 -- D ORGANIC NITROGEN CONTENT (micromoles/cubic decimetre)
Micromoles of organic nitrogen per cubic decimetre of water at 20 deg.C
-- MM see above

AMON 7 -- D AMMONIUM (NH₄-N) CONTENT (micromoles/cubic decimetre)
Micromoles of ammonium nitrogen per cubic decimetre of water at 20 deg.C
-- MM see above

SLCA 7 -- D SILICATE (SiO₄-Si) CONTENT (micromoles/cubic decimetre)
Micromoles of silicate silica per cubic decimetre of water at 20 deg.C
-- MM see above

CTOT 7 -- D TOTAL CARBON (C) CONTENT (micromoles/cubic decimetre)
Micromoles of total carbon per cubic decimetre of water at 20 deg.C
-- MM see above

CORG 7 -- D ORGANIC CARBON CONTENT (micromoles/cubic decimetre)
Micromoles of organic carbon per cubic decimetre of water at 20 deg.C
-- MM see above

HSUL 7 -- D HYDROGEN SULPHIDE (H₂S-S) CONTENT (micromoles/cubic decimetre)
Micromoles of hydrogen sulphide sulphur per cubic decimetre of water at
20 deg.C
-- MM see above

TABLE 7J

SPECIAL PURPOSE PARAMETERS

i) P P P P K M M \$ SPECIAL INDICATORS/IDENTIFIERS FROM WMO INTERNATIONAL CODE FORMS

- GGMS 7 -- N IGOSS MESSAGE IDENTIFIER
GG Four character code to identify the type of WMO standard radio message form used to report the data thus:
AAXX - SYNOP message
BBXX - SHIP message
JJXX - BATHY message
KKXX - TESAC message
ZZXX - DRIBU message
- GGLC 7 XX N QUALITY OF LOCATION -Q_L (WMO CODE 3311)
One character code qualifying buoy position reported in satellite transmission message. Coded as in WMO Code Table 3311 - see Annex X
- GGST 7 XX N QUALITY OF THE BUOY SATELLITE TRANSMISSION -Q_M (WMO CODE 3313)
One character code describing quality of satellite transmitted message. Coded as in WMO Code Table 3313 - see Annex X
- GGWI 7 XX N WIND SPEED INDICATOR -i_w (WMO CODE 1853)
One character code indicating the units in which wind speed was originally reported and the type of instrumentation used; coded as in WMO Code Table 1853 - see Annex X. (Note: the code does not necessarily relate to the units in which wind speed may be subsequently stored).
- GGDI 7 XX N INDICATOR FOR DIGITIZATION -k₁ (WMO CODE 2262)
One character code indicating method of digitizing temperature and/or salinity profiles; coded as in WMO Code Table 2262 - see Annex X
- GGSL 7 XX N METHOD OF SALINITY/DEPTH MEASUREMENT -k₂ (WMO CODE 2263)
One character code describing salinity method; coded as in WMO Code Table 2263 - see Annex X
- GGEC 7 XX N DURATION AND TIME OF EULERIAN CURRENT MEASUREMENT -k₃ (WMO CODE 2264)
One character code describing duration and time of current measurement made according to vector or doppler current profiling method; coded as in WMO Code Table 2264 - see Annex X
- GGCD 7 XX N PERIOD OF CURRENT MEASUREMENT (DRIFT) -k₄ (WMO CODE 2265)
One character code specifying period of current measurement using drift method; coded as in WMO Code Table 2265 - see Annex X
- GGCM 7 XX N INDICATOR FOR METHOD OF CURRENT MEASUREMENT -k₅ (WMO CODE 2266)
One character code indicating method of current measurement; coded as in WMO Code Table 2266 - see Annex X

GGIN 7 -- N IGOSS BATHY/TESAC INDICATORS

GG A twenty character string of single digit flags set according to indicators reported in IGOSS BATHY/TESAC message thus:

*Char 1: IGOSS WIND SPEED INDICATOR - i₁ indicates the units in which wind speed was originally reported and the type of instrumentation used; coded as in WMO Code Table 1853 - see Annex X

*Char. 2: PROBE HIT BOTTOM INDICATOR indicates whether depth profiling data was terminated by probe hitting the sea floor - coded as follows:

Code
0 unspecified
1 probe hit sea floor

*Char. 3: INDICATOR FOR DIGITIZATION - k₁ indicates method of digitizing temperature and/or salinity profiles; coded as in WMO Code Table 2262 - see Annex X

*Char. 4: METHOD OF SALINITY/DEPTH MEASUREMENT - k₂; coded as in WMO Code Table 2263 - see Annex X

*Char. 5: DURATION AND TIME OF CURRENT MEASUREMENT (VECTOR OR DOPPLER CURRENT PROFILING METHOD) - k₃; coded as in WMO Code Table 2264 - see Annex X

*Char. 6: PERIOD OF CURRENT MEASUREMENT (DRIFT METHOD) - k₄; coded as in WMO Code Table 2265 - see Annex X

*Char. 7: INDICATOR FOR METHOD OF CURRENT MEASUREMENT - k₅; coded as in WMO Code Table 2266 - see Annex X

*Chars. 8-20: RESERVED FOR FUTURE USE - blank filled for the present

ANNEX VIII

INDEX TO PARAMETER CODE ORDERED BY CODE

This Annex provides a simple index to the standard codes of the GF3 Parameter Code Table alphabetically sorted on the first four characters of the code (i.e. PPPP). Against each entry is given the name of the parameter, its units and a reference to that section of GF3 Code Table 7 where further details may be obtained on the definition of the parameter and its method/qualifier codes thus:-

- 7A-GEN. General purpose parameters - see Table 7A
- 7B-DATE Date and Time within Day parameters - see Table 7B
- 7C-TIME Time and Frequency parameters - see Table 7C
- 7D-POSN. Position/Navigation parameters - see Table 7D
- 7E-OCEAN Physical Oceanography parameters - see Table 7E
- 7F-WAVES Wave parameters - see Table 7F
- 7G-MET. Meteorology parameters - see Table 7G
- 7H-GEOPH. Geophysics parameters - see Table 7H
- 7I-CHEM. Chemistry parameters - see Table 7I
- 7J-SPEC. Special purpose parameters - see Table 7J

If the parameter code does not have associated method/parameter qualifier codes then MM is set in the index to 'XX' - on the other hand if standard method/parameter qualifier codes have been assigned to the parameter the entry for MM is set to '--'. Also listed in the index is the date on which the parameter was formally incorporated into the parameter code table and assigned a standard code (with K set to '7').

PPPP	KMMS	Parameter Name	Units	Reference	Date Assigned
ABSH	7XXA	ABSOLUTE HUMIDITY	g/m**3	7G-MET.	12/03/87
ALKY	7XXD	TOTAL ALKALINITY	mmol/m**3	7I-CHEM.	20/09/85
ALTG	7XXN	HEIGHT/ALTITUDE ABOVE GROUND LEVEL	metres	7D-POSN.	12/03/87
ALTS	7XXN	HEIGHT/ALTITUDE ABOVE MEAN SEA LEVEL	metres	7D-POSN.	12/03/87
AMON	7--D	AMMONIUM (NH4-N) CONTENT	mmol/m**3	7I-CHEM.	20/09/85
ASTD	7XXB	AIR-SEA TEMPERATURE DIFFERENCE	degrees C	7G-MET.	12/03/87
ATCK	7XXN	ANGLE OF ATTACK (AIRCRAFT)	degrees	7D-POSN.	12/03/87
ATMP	7XXA	ATMOSPHERIC PRESSURE AT ALTITUDE	hPa	7G-MET.	12/03/87
ATMS	7XXA	ATMOSPHERIC PRESSURE AT SEA LEVEL	hPa	7G-MET.	09/12/81
ATPT	7XXA	ATMOSPHERIC PRESSURE TENDENCY	hPa/hr	7G-MET.	12/03/87
ATRK	7XXN	ALONG TRACK DISPLACEMENT	metres	7D-POSN.	20/09/85
BAND	7XXN	BANDWIDTH OF SPECTRAL ANALYSIS	hertz	7C-TIME	09/12/81
BATH	7--N	BATHYMETRIC DEPTH	metres	7H-GEOPH.	20/09/85
BDIR	7XXN	BANDWIDTH OF DIRECTIONAL ANALYSIS	degrees	7F-WAVES	27/01/87
BEST	7XXN	BANDWIDTH OF SPECTRAL COMPONENT	hertz	7C-TIME	27/01/87
BRIT	7XXA	BRIGHTNESS (RADIATIVE) TEMPERATURE	degrees C	7G-MET.	12/03/87
CALK	7XXD	CARBONATE ALKALINITY	mmol/m**3	7I-CHEM.	12/03/87
CAST	7--N	HYDROGRAPHIC CAST TYPE	code	7E-OCEAN	12/03/87
CCCC	7--N	DATA CYCLE OVERFLOW INDICATOR	code	7A-GEN.	10/06/83
CCVR	7XXA	TOTAL CLOUD COVER IN TENTHS OF SKY	----	7G-MET.	12/03/87
CFLG	7--N	DATA CONTINUATION FLAG	code	7A-GEN.	20/09/85
CHAN	7XXN	NUMBER OF SENSOR CHANNELS	----	7A-GEN.	12/03/87
CHCH	7XXA	TYPE OF HIGH ALTITUDE CLOUD (WMO CODE 0509)	code	7G-MET.	12/03/87
CHLR	7--D	CHLORINITY (PARTS/THOUSAND)	g/kg	7E-OCEAN	09/12/81
CHLS	7--D	CHLOROSITY	kg/m**3	7E-OCEAN	12/03/87
CLCL	7XXA	TYPE OF LOW ALTITUDE CLOUD (WMO CODE 0513)	code	7G-MET.	12/03/87
CLCM	7XXA	AMOUNT OF LOW/MEDIUM ALTITUDE CLOUD (OKTAS - WMO CODE 2700)	code	7G-MET.	12/03/87
CLDA	7XXA	TOTAL CLOUD AMOUNT (OKTAS-WMO CODE 2700)	code	7G-MET.	20/09/85
CLDB	7XXA	CLOUD BASE ALTITUDE	metres	7G-MET.	12/03/87
CLDH	7XXA	CLOUD BASE HEIGHT (WMO CODE 1600)	code	7G-MET.	12/03/87
CLDT	7XXA	CLOUD TYPE (WMO CODE 0500)	code	7G-MET.	12/03/87
CMCH	7XXA	TYPE OF MEDIUM ALTITUDE CLOUD (WMO CODE 0515)	code	7G-MET.	12/03/87
CNDC	7XXD	ELECTRICAL CONDUCTIVITY	mhos/m	7E-OCEAN	09/12/81
CNQF	7--N	CHEMICAL CONTENT QUALIFIER FLAG	code	7I-CHEM.	20/09/85
CORG	7--D	ORGANIC CARBON CONTENT	mmol/m**3	7I-CHEM.	12/03/87
CPHL	7XXD	CHLOROPHYLL-A CONTENT	mg/m**3	7I-CHEM.	12/03/87
CTOT	7--D	TOTAL CARBON (C) CONTENT	mmol/m**3	7I-CHEM.	12/03/87
CVTQ	7--A	CO-VARIANCE OF AIR TEMPERATURE AND SPECIFIC HUMIDITY	degC.g/kg	7G-MET.	12/03/87
CVWQ	7--A	CO-VARIANCE OF WIND SPEED AND SPECIFIC HUMIDITY	(m/s).g/kg	7G-MET.	12/03/87
CVWS	7--A	CO-VARIANCE OF WIND SPEED COMPONENTS	(m/s)**2	7G-MET.	12/03/87
CVWT	7--A	CO-VARIANCE OF WIND SPEED AND AIR TEMPERATURE	degC.m/s	7G-MET.	12/03/87
DATE	7--N	DATE WITHIN YEAR IN FORMAT MMDD	----	7B-DATE	09/12/81
DATM	7--N	BATHYMETRIC DATUM	code	7H-GEOPH.	20/09/85
DAYS	7--N	DAY NUMBER WITHIN YEAR (Jan 1st = 1)	days	7B-DATE	09/12/81

PPPP	KMMS	Parameter Name	Units	Reference	Date Assigned
DENS	7--D	SEA DENSITY	kg/m**3	7E-OCEAN	09/12/81
DEPH	7--N	SENSOR DEPTH BELOW SEA SURFACE	metres	7D-POSN.	09/12/81
DEWD	7XXA	DEW POINT DEPRESSION	degrees C	7G-MET.	12/03/87
DEWT	7XXA	DEW POINT TEMPERATURE	degrees C	7G-MET.	12/03/87
DIRM	7XXN	BEARING OF OBJECT FROM REFERENCE POINT (relative to magnetic North)	degrees	7D-POSN.	09/12/81
DIRT	7XXN	BEARING OF OBJECT FROM REFERENCE POINT (relative to True North)	degrees	7D-POSN.	09/12/81
DISE	7XXN	DISTANCE OF OBJECT IN DIRECTION TRUE EAST FROM REFERENCE POINT	metres	7D-POSN.	09/12/81
DISN	7XXN	DISTANCE OF OBJECT IN DIRECTION TRUE NORTH FROM REFERENCE POINT	metres	7D-POSN.	09/12/81
DOXY	7--D	DISSOLVED OXYGEN	mmol/m**3	7E-OCEAN	10/06/83
DPSF	7XXN	DEPTH BELOW SEA FLOOR	metres	7D-POSN.	09/12/81
DRDP	7XXD	DEPTH OF DROGUE	metres	7E-OCEAN	12/03/87
DRHR	7--N	DURATION (HOURS)	hours	7C-TIME	09/12/81
DRMN	7--N	DURATION (MINUTES)	minutes	7C-TIME	09/12/81
DRSC	7--N	DURATION (SECONDS)	seconds	7C-TIME	09/12/81
DRYT	7XXA	DRY BULB TEMPERATURE	degrees C	7G-MET.	09/12/81
DTDZ	7--A	VERTICAL AIR TEMPERATURE GRADIENT	degC/m	7G-MET.	12/03/87
EAZM	7XXN	AZIMUTH OF MAJOR AXIS OF NAVIGATION ERROR ELLIPSE	degrees	7D-POSN.	20/09/85
EEEE	7XXN	DECIMAL EXPONENT	----	7A-GEN.	09/12/81
ELEV	7XXN	ELEVATION ANGLE OF OBJECT FROM REFERENCE POINT	degrees	7D-POSN.	12/03/87
EMAJ	7XXN	LENGTH OF SEMIMAJOR-AXIS OF NAVIGATION ERROR ELLIPSE	metres	7D-POSN.	20/09/85
EMIN	7XXN	LENGTH OF SEMIMINOR AXIS OF NAVIGATION ERROR ELLIPSE	metres	7D-POSN.	20/09/85
ETHR	7XXN	ELAPSED TIME (HOURS)	hours	7C-TIME	09/12/81
ETMN	7XXN	ELAPSED TIME (MINUTES)	minutes	7C-TIME	09/12/81
ETSC	7XXN	ELAPSED TIME (SECONDS)	seconds	7C-TIME	09/12/81
EWCM	7--D	EAST (MAGNETIC) COMPONENT OF CURRENT	m/s	7E-OCEAN	09/12/81
EWCT	7--D	EAST (TRUE) COMPONENT OF CURRENT	m/s	7E-OCEAN	09/12/81
FFFF	7--N	QUALITY CONTROL FLAG	code	7A-GEN.	09/12/81
FIXF	7--N	PRIME NAVIGATION AID FIX FLAG	code	7D-POSN.	20/09/85
FREQ	7--N	FREQUENCY	hertz	7C-TIME	09/12/81
GBGA	7XXN	BOUGER GRAVITY ANOMALY	milligals	7H-GEOPH.	20/09/85
GDIR	7XXA	DIRECTION FROM WHICH GUST WIND IS BLOWING (relative to True North)	degrees	7G-MET.	09/12/81
GEOT	7--N	GRAVITY EOTVOS CORRECTION	milligals	7H-GEOPH.	20/09/85
GFAA	7--N	FREE AIR GRAVITY ANOMALY	milligals	7H-GEOPH.	20/09/85
GGCD	7XXN	PERIOD OF CURRENT MEASUREMENT (DRIFT) (WMO CODE 2265)	code	7J-SPEC.	12/03/87
GGCM	7XXN	INDICATOR FOR METHOD OF CURRENT MEASUREMENT (WMO CODE 2266)	code	7J-SPEC.	12/03/87
GGDI	7XXN	INDICATOR FOR DIGITIZATION (WMO CODE 2262)	code	7J-SPEC.	12/03/87
GGEC	7XXN	DURATION AND TIME OF EULERIAN CURRENT MEASUREMENT (WMO CODE 2264)	code	7J-SPEC.	12/03/87
GGIN	7--N	IGOSS BATHY/TESAC INDICATORS	code	7J-SPEC.	27/06/85
GGLC	7XXN	QUALITY OF LOCATION (WMO CODE 3311)	code	7J-SPEC.	12/03/87
GGMS	7--N	IGOSS MESSAGE IDENTIFIER	code	7J-SPEC.	27/06/85

PPPP	KMMS	Parameter Name	Units	Reference	Date Assigned
GGQF	7--N	QUALITY CONTROL FLAGS FOR DATE, TIME, POSITION AND SEA FLOOR DEPTH	code	7A-GEN.	27/06/85
GGSL	7XXN	METHOD OF SALINITY/DEPTH MEASUREMENT (WMO CODE 2263)	code	7J-SPEC.	12/03/87
GGST	7XXN	QUALITY OF BUOY SATELLITE TRANSMISSION (WMO CODE 3313)	code	7J-SPEC.	12/03/87
GGWI	7XXN	WIND SPEED INDICATOR (WMO CODE 1853)	code	7J-SPEC.	12/03/87
GRAV	7XXN	OBSERVED GRAVITY	milligals	7H-GEOPH.	20/09/85
GSPD	7XXA	GUST WIND SPEED	m/s	7G-MET.	09/12/81
HCDM	7--D	DIRECTION TO WHICH HORIZONTAL CURRENT IS FLOWING (relative to Magnetic North)	degrees	7E-OCEAN	09/12/81
HCDT	7--D	DIRECTION TO WHICH HORIZONTAL CURRENT IS FLOWING (relative to True North)	degrees	7E-OCEAN	09/12/81
HCSP	7--D	HORIZONTAL CURRENT SPEED	m/s	7E-OCEAN	09/12/81
HEAD	7XXN	PLATFORM HEADING (relative to True North)	degrees	7D-POSN.	20/09/85
HGHT	7XXN	HEIGHT/ALTITUDE ABOVE SEA SURFACE	metres	7D-POSN.	09/12/81
HHMM	7--N	TIME WITHIN DAY IN FORMAT HHMM	----	7B-DATE	09/12/81
HIGF	7XXN	HIGH FREQUENCY CUT OFF FOR INTEGRATION UNDER SPECTRUM	hertz	7C-TIME	09/12/81
HMXR	7XXA	HUMIDITY MIXING RATIO	g/kg	7G-MET.	12/03/87
HOUR	7--N	HOURS WITHIN DAY	hours	7B-DATE	09/12/81
HSUL	7--D	HYDROGEN SULPHIDE (H ₂ S-S) CONTENT	mmol/m**3	7I-CHEM.	12/03/87
HTSF	7XXN	HEIGHT ABOVE SEA FLOOR	metres	7D-POSN.	09/12/81
ICEF	7--N	FLAG FOR ICE IN VICINITY OF HYDROGRAPHIC OBSERVATIONS	code	7E-OCEAN	20/09/85
IDEN	7XXN	DATA IDENTIFIER	----	7A-GEN.	12/03/87
LATD	7--N	LATITUDE DEGREES (North +ve)	degrees	7D-POSN.	09/12/81
LATM	7--N	LATITUDE MINUTES WITHIN DEGREE (North +ve)	mins arc	7D-POSN.	09/12/81
LINC	7XXA	LONG-WAVE INCOMING RADIATION	W/m**2	7G-MET.	12/03/87
LOND	7--N	LONGITUDE DEGREES (East +ve)	degrees	7D-POSN.	09/12/81
LONM	7--N	LONGITUDE MINUTES WITHIN DEGREE (East +ve)	mins arc	7D-POSN.	09/12/81
LOUT	7XXA	LONG-WAVE OUTGOING RADIATION	W/m**2	7G-MET.	12/03/87
LOWF	7XXN	LOW FREQUENCY CUT OFF FOR INTEGRATION UNDER SPECTRUM	hertz	7C-TIME	09/12/81
LVLS	7--N	SELECTION OF DEPTH LEVELS	code	7E-OCEAN	12/03/87
LWCT	7XXA	LIQUID WATER CONTENT	g/m**3	7G-MET.	12/03/87
MAGC	7XXN	MAGNETIC FIELD CORRECTION	nanoteslas	7H-GEOPH.	20/09/85
MAGN	7XXN	MAGNETIC VARIATION FROM TRUE NORTH	degrees	7D-POSN.	09/12/81
MAGR	7--N	RESIDUAL MAGNETIC FIELD	nanoteslas	7H-GEOPH.	20/09/85
MAGT	7XXN	TOTAL MAGNETIC FIELD	nanoteslas	7H-GEOPH.	20/09/85
MINS	7--N	MINUTES WITHIN HOUR	minutes	7B-DATE	09/12/81
MMFX	7XXN	METHOD CODE FOR POSITION FIXING	code	7D-POSN.	12/03/87
MMMM	7--N	METHOD CODE IN USER DEFINED AREA	code	7A-GEN.	09/12/81
MNTH	7--N	CALENDAR MONTH (MM) WITHIN YEAR	----	7B-DATE	10/06/83
NETR	7XXA	NET RADIATION	W/m**2	7G-MET.	12/03/87
NIRR	7XXA	NEAR-INFRARED RADIATION	W/m**2	7G-MET.	12/03/87
NORG	7--D	ORGANIC NITROGEN CONTENT	mmol/m**3	7I-CHEM.	12/03/87
NSCM	7--D	NORTH (MAGNETIC) COMPONENT OF CURRENT	m/s	7E-OCEAN	09/12/81
NSCT	7--D	NORTH (TRUE) COMPONENT OF CURRENT	m/s	7E-OCEAN	09/12/81

PPPP	KMMS	Parameter Name	Units	Reference	Date Assigned
NTHR	7--N	INTERVAL (HOURS)	hours	7C-TIME	09/12/81
NTMN	7--N	INTERVAL (MINUTES)	minutes	7C-TIME	09/12/81
NTOT	7--D	TOTAL NITROGEN (N) CONTENT	mmol/m**3	7I-CHEM.	12/03/87
NTRA	7--D	NITRATE (NO3-N) CONTENT	mmol/m**3	7I-CHEM.	20/09/85
NTRI	7--D	NITRITE (NO2-N) CONTENT	mmol/m**3	7I-CHEM.	20/09/85
NTRZ	7--D	NITRATE + NITRITE CONTENT	mmol/m**3	7I-CHEM.	12/03/87
NTSC	7--N	INTERVAL (SECONDS)	seconds	7C-TIME	09/12/81
PAIR	7XXN	COUNT OF PARAMETER PAIRS IN DATA CYCLE	----	7A-GEN.	20/09/85
PHOS	7--D	PHOSPHATE (PO4-P) CONTENT	mmol/m**3	7I-CHEM.	20/09/85
PHPH	7XXD	HYDROGEN ION CONCENTRATION (pH)	----	7I-CHEM.	20/09/85
PLAT	7--N	PLATFORM IDENTIFIER	code	7A-GEN.	12/03/87
POTM	7--D	POTENTIAL TEMPERATURE	degrees C	7E-OCEAN	09/12/81
POTT	7XXA	POTENTIAL AIR TEMPERATURE	degrees C	7G-MET.	12/03/87
PRES	7--D	SEA PRESSURE (sea surface = 0)	decibars	7E-OCEAN	09/12/81
PRHB	7--N	PROBE HIT BOTTOM INDICATOR	code	7E-OCEAN	12/03/87
PRRT	7XXA	PRECIPITATION RATE	mm/hr	7G-MET.	12/03/87
PRTN	7XXA	PRECIPITATION AMOUNT	mm	7G-MET.	12/03/87
PSAL	7--D	PRACTICAL SALINITY	----	7E-OCEAN	09/12/81
PTCH	7XXN	PITCH ANGLE	degrees	7D-POSN.	12/03/87
PVAR	7XXN	VARIANCE OF PRECEDING PARAMETER	----	7A-GEN.	12/03/87
QPOS	7--N	QUALITY CONTROL FLAG FOR GEOGRAPHIC POSITION	code	7A-GEN.	12/03/87
QSOL	7XXG	GROUND HEAT FLUX	W/m**2	7G-MET.	12/03/87
QTIM	7--N	QUALITY CONTROL FLAG FOR SERIES DATE/TIME	code	7A-GEN.	12/03/87
RADD	7XXN	HORIZONTAL DISTANCE OF OBJECT FROM REFERENCE POINT	metres	7D-POSN.	09/12/81
RANG	7XXN	DIRECT DISTANCE OF OBJECT FROM REFERENCE POINT	metres	7D-POSN.	09/12/81
RELH	7XXA	RELATIVE HUMIDITY	percent	7G-MET.	09/12/81
RELP	7--D	RELATIVE TOTAL PRESSURE	decibars	7E-OCEAN	12/03/87
ROLL	7XXN	ROLL ANGLE	degrees	7D-POSN.	12/03/87
SALD	7--N	SALINITY UNITS FLAG	code	7E-OCEAN	20/09/85
SCDT	7--D	DIRECTION TO WHICH SEA SURFACE CURRENT IS FLOWING (relative to True North)	degrees	7E-OCEAN	27/06/85
SCSP	7--D	SEA SURFACE CURRENT SPEED	m/s	7E-OCEAN	27/06/85
SDAT	7--A	STANDARD DEVIATION OF AIR TEMPERATURE	degrees C	7G-MET.	12/03/87
SDEV	7XXN	STANDARD DEVIATION OF PRECEDING PARAMETER	----	7A-GEN.	12/03/87
SDHU	7XXA	STANDARD DEVIATION OF SPECIFIC HUMIDITY	g/kg	7G-MET.	12/03/87
SDIF	7XXA	SHORT-WAVE DIFFUSE RADIATION	W/m**2	7G-MET.	12/03/87
SDIR	7XXA	SHORT-WAVE DIRECT RADIATION	W/m**2	7G-MET.	12/03/87
SDWS	7--A	STANDARD DEVIATION OF WIND SPEED	m/s	7G-MET.	12/03/87
SEAS	7XXD	SEA STATE (WMO CODE 3700)	code	7F-WAVES	20/09/85
SECC	7XXD	SECCHI DISC DEPTH	metres	7E-OCEAN	20/09/85
SECS	7--N	SECONDS WITHIN MINUTE	seconds	7B-DATE	09/12/81
SIDE	7XXN	ANGLE OF SIDESLIP (AIRCRAFT)	degrees	7D-POSN.	12/03/87
SINC	7XXA	SHORT-WAVE INCOMING RADIATION	W/m**2	7G-MET.	12/03/87
SLCA	7--D	SILICATE (SIO4-SI) CONTENT	mmol/m**3	7I-CHEM.	20/09/85
SLEV	7XXD	OBSERVED SEA LEVEL	metres	7E-OCEAN	09/12/81

PPPP	KMMS	Parameter Name	Units	Reference	Date Assigned
SOLT	7XXG	GROUND (SOIL) TEMPERATURE	degrees C	7G-MET.	12/03/87
SOUT	7XXA	SHORT-WAVE OUTGOING RADIATION	W/m**2	7G-MET.	12/03/87
SPCF	7XXN	FREQUENCY OF SPECTRAL COMPONENT	hertz	7C-TIME	09/12/81
SPDG	7XXN	TRUE PLATFORM SPEED ACROSS THE GROUND	m/s	7D-POSN.	12/03/87
SPDI	7XXN	INDICATED PLATFORM SPEED (AIRCRAFT)	m/s	7D-POSN.	12/03/87
SPDR	7XXN	RELATIVE PLATFORM SPEED THROUGH THE AIR/WATER	m/s	7D-POSN.	12/03/87
SPDV	7XXN	VERTICAL PLATFORM SPEED	m/s	7D-POSN.	12/03/87
SPEH	7XXA	SPECIFIC HUMIDITY	g/kg	7G-MET.	12/03/87
SSAL	7--D	SALINITY (PRE-1978 DEFINITION) (PARTS/THOUSAND)	g/kg	7E-OCEAN	09/12/81
SSPS	7--D	SEA SURFACE PRACTICAL SALINITY	----	7E-OCEAN	09/12/81
SSSL	7--D	SEA SURFACE SALINITY (PRE-1978 DEFINITION) (PARTS/THOUSAND)	g/kg	7E-OCEAN	09/12/81
SSTP	7--D	SEA SURFACE TEMPERATURE	degrees C	7E-OCEAN	09/12/81
STAG	7XXA	STAGNATION TEMPERATURE	degrees C	7G-MET.	12/03/87
SVCZ	7XXN	BATHYMETRY SOUND VELOCITY CORRECTION AREA	----	7H-GEOPH.	20/09/85
SVEI	7--D	SOUND VELOCITY	m/s	7E-OCEAN	10/06/83
SWDR	7--D	DIRECTION FROM WHICH SWELL IS COMING (relative to True North)	degrees	7F-WAVES	12/03/87
SWHT	7--D	SWELL HEIGHT	metres	7F-WAVES	12/03/87
SWPR	7--D	SWELL PERIOD	seconds	7F-WAVES	12/03/87
TDFL	7--D	TRACE DIRECTION FLAG	code	7E-OCEAN	12/03/87
TDIF	7--A	AIR TEMPERATURE DIFFERENCE BETWEEN TWO LEVELS (UPPER-LOWER)	degrees C	7G-MET.	12/03/87
TEMP	7--D	SEA TEMPERATURE	degrees C	7E-OCEAN	09/12/81
TEXT	7XXN	PLAIN LANGUAGE TEXT	----	7A-GEN.	09/12/81
TGRD	7--D	SEA TEMPERATURE GRADIENT	degC/m	7E-OCEAN	12/03/87
TIME	7--N	TIME WITHIN DAY IN FORMAT HHMMSS	----	7B-DATE	09/12/81
TOTP	7--D	TOTAL PRESSURE (atmosphere+sea pressure)	decibars	7E-OCEAN	09/12/81
TPHS	7--D	TOTAL PHOSPHOROUS (P) CONTENT	mmol/m**3	7I-CHEM.	20/09/85
TWCT	7XXA	TOTAL WATER CONTENT	g/m**3	7G-MET.	12/03/87
TWTT	7XXN	BATHYMETRIC TWO WAY TRAVEL TIME	seconds	7H-GEOPH.	20/09/85
ULTR	7XXA	ULTRA-VIOLET RADIATION	W/m**2	7G-MET.	12/03/87
USAL	7--D	UNDEFINED SALINITY (Prac. Salin or parts/thousand) - see also SALD7AAN	----	7E-OCEAN	20/09/85
VAPP	7XXA	ACTUAL WATER VAPOUR PRESSURE	hPa	7G-MET.	12/03/87
VAVH	7--D	AVERAGE HEIGHT HIGHEST ONE THIRD WAVES	metres	7F-WAVES	09/12/81
VBRF	7--D	WAVES SPECTRAL WIDTH (BROADNESS)	----	7F-WAVES	09/12/81
VCAR	7--D	CHARACTERISTIC WAVE HEIGHT (4*RMS)	metres	7F-WAVES	09/12/81
VCMX	7--D	MAXIMUM CREST TO TROUGH WAVE HEIGHT	metres	7F-WAVES	09/12/81
VCXX	7--D	AUTO-SPECTRUM OF NORTH-SOUTH TILT	deg**2/Hz	7F-WAVES	27/01/87
VCXY	7--D	CO-SPECTRUM OF NORTH-SOUTH AND EAST-WEST TILTS	deg**2/Hz	7F-WAVES	27/01/87
VCYY	7--D	AUTO-SPECTRUM OF EAST-WEST TILT	deg**2/Hz	7F-WAVES	27/01/87
VCZX	7--D	CO-SPECTRUM OF HEAVE AND NORTH-SOUTH TILT	m.deg/Hz	7F-WAVES	27/01/87
VCZY	7--D	CO-SPECTRUM OF HEAVE AND EAST-WEST TILT	m.deg/Hz	7F-WAVES	27/01/87
VDEP	7XXN	SPECIFIED DIRECTION OF WAVE ENERGY PROPAGATION	degrees	7F-WAVES	12/03/87

PPPP	KMMS	Parameter Name	Units	Reference	Date Assigned
VDIR	7--D	VISUAL ESTIMATE OF DIRECTION FROM WHICH WAVES ARE COMING(relative to True North)	degrees	7F-WAVES	20/09/85
VDSO	7--D	DIRECTIONAL WAVE SPECTRUM DENSITY	m**2/Hz	7F-WAVES	12/03/87
VERT	7XXN	VERTICAL DISTANCE OF OBJECT ABOVE REFERENCE POINT	metres	7D-POSN.	12/03/87
VEST	7--D	VISUAL AVERAGE WAVE HEIGHT	metres	7F-WAVES	09/12/81
VIRT	7XXA	VIRTUAL AIR TEMPERATURE	degrees C	7G-MET.	12/03/87
VISB	7XXA	HORIZONTAL VISIBILITY	metres	7G-MET.	12/03/87
VMED	7--D	WAVE SPECTRUM MEAN ENERGY DIRECTION	degrees	7F-WAVES	27/01/87
VMNL	7--D	MINIMUM WAVE LEVEL	metres	7F-WAVES	09/12/81
VMTA	7--D	ZEROETH MOMENT OF WAVE SPECTRUM	m**2	7F-WAVES	09/12/81
VMTB	7--D	FIRST MOMENT OF WAVE SPECTRUM	m**2.Hz	7F-WAVES	09/12/81
VMTC	7--D	SECOND MOMENT OF WAVE SPECTRUM	(m.Hz)**2	7F-WAVES	09/12/81
VMTD	7--D	THIRD MOMENT OF WAVE SPECTRUM	m**2.Hz**3	7F-WAVES	09/12/81
VMTE	7--D	FOURTH MOMENT OF WAVE SPECTRUM	m**2.Hz**4	7F-WAVES	09/12/81
VMTM	7--D	FIRST NEGATIVE MOMENT OF WAVE SPECTRUM	m**2/Hz	7F-WAVES	09/12/81
VMTN	7--D	SECOND NEGATIVE MOMENT OF WAVE SPECTRUM	(m/Hz)**2	7F-WAVES	09/12/81
VMWD	7--D	MEAN WAVE DIRECTION FROM CROSS SPECTRA	degrees	7F-WAVES	12/03/87
VMXL	7--D	MAXIMUM WAVE LEVEL	metres	7F-WAVES	09/12/81
VNUM	7--D	WAVE NUMBER FROM CROSS SPECTRA	degrees/m	7F-WAVES	12/03/87
VPED	7--D	WAVE SPECTRUM PEAK ENERGY DIRECTION	degrees	7F-WAVES	27/01/87
VPER	7--D	VISUAL ESTIMATE OF WAVE PERIOD	seconds	7F-WAVES	20/09/85
VQXY	7--D	QUAD-SPECTRUM OF NORTH-SOUTH AND EAST-WEST TILTS	deg**2/Hz	7F-WAVES	27/01/87
VQZX	7--D	QUAD-SPECTRUM OF HEAVE AND NORTH-SOUTH TILT	m.deg/Hz	7F-WAVES	27/01/87
VQZY	7--D	QUAD-SPECTRUM OF HEAVE AND EAST-WEST TILT	m.deg/Hz	7F-WAVES	27/01/87
VRAT	7--A	VARIANCE OF AIR TEMPERATURE	degC**2	7G-MET.	12/03/87
VRHU	7XXA	VARIANCE OF SPECIFIC HUMIDITY	(g/kg)**2	7G-MET.	12/03/87
VRMS	7--D	RMS WAVE DISPLACEMENT	metres	7F-WAVES	09/12/81
VRWS	7--A	VARIANCE OF WIND SPEED	(m/s)**2	7G-MET.	12/03/87
VSDN	7--D	WAVE VARIANCE SPECTRAL DENSITY : S(f)	m**2/Hz	7F-WAVES	09/12/81
V SMA	7--D	SPECTRAL MOMENTS (-1,0) WAVE PERIOD	seconds	7F-WAVES	09/12/81
V SMB	7--D	SPECTRAL MOMENTS (0,1) WAVE PERIOD	seconds	7F-WAVES	09/12/81
V SMC	7--D	SPECTRAL MOMENTS (0,2) WAVE PERIOD	seconds	7F-WAVES	09/12/81
V SMD	7--D	SPECTRAL MOMENTS (2,4) WAVE PERIOD	seconds	7F-WAVES	09/12/81
VSPR	7--D	WAVE DIRECTIONAL SPREAD FROM CROSS SPECTRA	degrees	7F-WAVES	12/03/87
VSWD	7--D	WAVES SPECTRAL WIDTH FROM MOMENTS	----	7F-WAVES	09/12/81
VTCA	7--D	AVERAGE WAVE CREST PERIOD	seconds	7F-WAVES	09/12/81
VTDH	7--D	TUCKER DRAPER SIGNIFICANT WAVE HEIGHT	metres	7F-WAVES	09/12/81
VTKC	7--D	SECOND HIGHEST WAVE CREST	metres	7F-WAVES	09/12/81
VTKD	7--D	SECOND LOWEST WAVE TROUGH	metres	7F-WAVES	09/12/81
VTPK	7--D	WAVE SPECTRUM PEAK PERIOD	seconds	7F-WAVES	09/12/81
VTZA	7--D	AVERAGE ZERO CROSSING WAVE PERIOD	seconds	7F-WAVES	09/12/81
VTZM	7--D	PERIOD OF MAXIMUM ZERO CROSSING WAVE	seconds	7F-WAVES	09/12/81
VWSA	7--D	INSTANTANEOUS HEAVE ACCELERATION	m/s**2	7F-WAVES	27/01/87
VWSE	7--D	INSTANTANEOUS WATER SURFACE ELEVATION	metres	7F-WAVES	09/12/81
VWSH	7XXA	VERTICAL WIND SHEAR	(m/s)/km	7G-MET.	12/03/87

PPPP	KMMS	Parameter Name	Units	Reference	Date Assigned
VWTE	7--D	WATER SURFACE EAST-WEST TILT ANGLE	degrees	7F-WAVES	27/01/87
VWTN	7--D	WATER SURFACE NORTH-SOUTH TILT ANGLE	degrees	7F-WAVES	27/01/87
VZMX	7--D	MAXIMUM ZERO CROSSING WAVE HEIGHT	metres	7F-WAVES	09/12/81
WCLR	7XXD	WATER COLOUR (FOREL-ULE SCALE)	code	7E-OCEAN	20/09/85
WDIR	7XXA	DIRECTION FROM WHICH WIND IS BLOWING (relative to True North)	degrees	7G-MET.	09/12/81
WETT	7XXA	WET BULB TEMPERATURE	degrees C	7G-MET.	09/12/81
WFBS	7XXA	WIND FORCE ON BEAUFORT SCALE	code	7G-MET.	12/03/87
WMDP	7--D	MEAN WATER DEPTH	metres	7F-WAVES	09/12/81
WRDP	7--D	MEAN RECORD WATER DEPTH	metres	7F-WAVES	09/12/81
WSDP	7--D	STILL WATER DEPTH	metres	7F-WAVES	09/12/81
WSPD	7XXA	HORIZONTAL WIND SPEED	m/s	7G-MET.	09/12/81
WSPE	7XXA	EASTWARD (TRUE) COMPONENT OF WIND SPEED	m/s	7G-MET.	12/03/87
WSPN	7XXA	NORTHWARD (TRUE) COMPONENT OF WIND SPEED	m/s	7G-MET.	12/03/87
WTHA	7XXA	PAST WEATHER (WMO CODE 4561)	code	7G-MET.	20/09/85
WVER	7XXA	VERTICAL WIND SPEED	m/s	7G-MET.	12/03/87
WWCD	7XXA	PRESENT WEATHER (WMO CODE 4677)	code	7G-MET.	20/09/85
XTRK	7XXN	ACROSS TRACK DISPLACEMENT (starboard +ve)	metres	7D-POSN.	20/09/85
YEAR	7--N	CALENDAR YEAR	years	7B-DATE	09/12/81
ZNTH	7XXN	ZENITH ANGLE OF OBJECT FROM REFERENCE POINT	degrees	7D-POSN.	12/03/87
ZONE	7XXN	TIME ZONE CORRECTION	hours	7B-DATE	09/12/81

ANNEX IX

INDEX TO PARAMETER CODE ORDERED BY DIMENSION EXPONENTS

This Annex provides an index to the GF3 Parameter Code Table based on the dimensional exponents (c.f. units) of each parameter. Providing the user is aware of the units of the parameter he is searching for, the index provides a quick look up facility for ascertaining whether that particular parameter has been assigned a standard GF3 parameter code. If it has, then the index gives a reference to where further details may be found. If not, then the user may need to create his own parameter code as described at the beginning of Annex VII.

The dimensions in this index are based on the seven base units and the two supplementary units of the SI system. Two additional elements are also introduced for the convenience of users i.e. counts (e.g. of biological species) and codes (for those parameters whose values are stored in a codified form):-

	dimension	S.I. unit
MASS	mass	kilogram (kg)
LNTH	length	metre (m)
TIME	time	second (s)
TEMP	temperature	kelvin (K)
ELEC	electric current	ampere (A)
CHEM	chemical amount	mole (mol)
LUM	luminous intensity	candela (cd)
RADS	plane angle	radian (rad)
STER	solid angle	steradian (sr)
CNTS	counts	-
CODE	coded parameter	-

The dimensions are arranged in the above order and the index is sorted in ascending sequence of dimension exponent. Against each entry is given the parameter code (first four characters PPPP), its name and units, and a reference (as in Annex VIII) to the appropriate section of Annex VII where further details may be obtained on the definition of the parameter and its method/qualifier codes.

Entry into the index is particularly straightforward for parameters whose units are expressed directly in terms of SI base or supplementary units. For those expressed in SI derived units the following conversions will be found useful:-

<u>Quantity</u>	<u>Units</u>	<u>Expression in terms of SI base units</u>
frequency	hertz	s^{-1}
force	newton	$kg.m.s^{-2}$
pressure, stress	pascal	$kg.m^{-1}.s^{-2}$
energy, work, quantity of heat	joule	$kg.m^2.s^{-2}$
power, radiant flux	watt	$kg.m^2.s^{-3}$

<u>Quantity</u>	<u>Units</u>	<u>Expression in terms of SI base units</u>
quantity of electricity, electric charge	coulomb	s.A
electric potential, potential difference, electromotive force	volt	kg.m ² .s ⁻³ .A ⁻¹
capacitance	farad	kg ⁻¹ .m ⁻² .s ⁴ .A ²
electric resistance	ohm	kg.m ² .s ⁻³ .A ⁻²
conductance	siemens	kg ⁻¹ .m ⁻² .s ³ .A ²
magnetic flux	weber	kg.m ² .s ⁻² .A ⁻¹
magnetic flux density	tesla	kg.s ⁻² .A ⁻¹
inductance	henry	kg.m ² .s ⁻² .A ⁻²
Celsius temperature	degree Celsius	K
luminous flux	lumen	cd.sr
illuminance	lux	m ⁻² .cd.sr
activity (of a radio- nuclide)	becquerel	s ⁻¹
absorbed dose, specific energy imparted, kerma, absorbed dose index	gray	m ² .s ⁻²

Thus, for example, a parameter with the dimensions of pressure would be searched for under MASS=1, LENGTH=-1 and TIME=-2 with the remaining dimensions zero.

PPPP	Parameter Name	Units	Dimension Exponents										Reference
			MASS	TIME	ELEC	LUM	STER	CODE					
			LNTH	TEMP	CHEM	RADS	CNTS						
CNDC	ELECTRICAL CONDUCTIVITY	mhos/m	-1	-3	3	0	2	0	0	0	0	0	7E-OCEAN
DOXY	DISSOLVED OXYGEN	mmol/m**3	0	-3	0	0	0	1	0	0	0	0	7E-OCEAN
ALKY	TOTAL ALKALINITY	mmol/m**3	0	-3	0	0	0	1	0	0	0	0	7I-CHEM.
AMON	AMMONIUM (NH4-N) CONTENT	mmol/m**3	0	-3	0	0	0	1	0	0	0	0	7I-CHEM.
CALK	CARBONATE ALKALINITY	mmol/m**3	0	-3	0	0	0	1	0	0	0	0	7I-CHEM.
CORG	ORGANIC CARBON CONTENT	mmol/m**3	0	-3	0	0	0	1	0	0	0	0	7I-CHEM.
CTOT	TOTAL CARBON (C) CONTENT	mmol/m**3	0	-3	0	0	0	1	0	0	0	0	7I-CHEM.
HSUL	HYDROGEN SULPHIDE (H2S-S) CONTENT	mmol/m**3	0	-3	0	0	0	1	0	0	0	0	7I-CHEM.
NORG	ORGANIC NITROGEN CONTENT	mmol/m**3	0	-3	0	0	0	1	0	0	0	0	7I-CHEM.
NTOT	TOTAL NITROGEN (N) CONTENT	mmol/m**3	0	-3	0	0	0	1	0	0	0	0	7I-CHEM.
NTRA	NITRATE (NO3-N) CONTENT	mmol/m**3	0	-3	0	0	0	1	0	0	0	0	7I-CHEM.
NTRI	NITRITE (NO2-N) CONTENT	mmol/m**3	0	-3	0	0	0	1	0	0	0	0	7I-CHEM.
NTRZ	NITRATE + NITRITE CONTENT	mmol/m**3	0	-3	0	0	0	1	0	0	0	0	7I-CHEM.
PHOS	PHOSPHATE (PO4-P) CONTENT	mmol/m**3	0	-3	0	0	0	1	0	0	0	0	7I-CHEM.
SLCA	SILICATE (SI04-SI) CONTENT	mmol/m**3	0	-3	0	0	0	1	0	0	0	0	7I-CHEM.
TPHS	TOTAL PHOSPHOROUS (P) CONTENT	mmol/m**3	0	-3	0	0	0	1	0	0	0	0	7I-CHEM.
VNUM	WAVE NUMBER FROM CROSS SPECTRA	degrees/m	0	-1	0	0	0	0	1	0	0	0	7F-WAVES
TGRD	SEA TEMPERATURE GRADIENT	degC/m	0	-1	0	1	0	0	0	0	0	0	7E-OCEAN
DTDZ	VERTICAL AIR TEMPERATURE GRADIENT	degC/m	0	-1	0	1	0	0	0	0	0	0	7G-MET.
BAND	BANDWIDTH OF SPECTRAL ANALYSIS	hertz	0	0	-1	0	0	0	0	0	0	0	7C-TIME
BEST	BANDWIDTH OF SPECTRAL COMPONENT	hertz	0	0	-1	0	0	0	0	0	0	0	7C-TIME
FREQ	FREQUENCY	hertz	0	0	-1	0	0	0	0	0	0	0	7C-TIME
HIGF	HIGH FREQUENCY CUT OFF FOR INTEGRATION UNDER SPECTRUM.	hertz	0	0	-1	0	0	0	0	0	0	0	7C-TIME
LOWF	LOW FREQUENCY CUT OFF FOR INTEGRATION UNDER SPECTRUM	hertz	0	0	-1	0	0	0	0	0	0	0	7C-TIME
SPCF	FREQUENCY OF SPECTRAL COMPONENT	hertz	0	0	-1	0	0	0	0	0	0	0	7C-TIME
CHAN	NUMBER OF SENSOR CHANNELS	----	0	0	0	0	0	0	0	0	0	0	7A-GEN.
EEEE	DECIMAL EXPONENT	----	0	0	0	0	0	0	0	0	0	0	7A-GEN.
IDEN	DATA IDENTIFIER	----	0	0	0	0	0	0	0	0	0	0	7A-GEN.
PAIR	COUNT OF PARAMETER PAIRS IN DATA CYCLE	----	0	0	0	0	0	0	0	0	0	0	7A-GEN.
PVAR	VARIANCE OF PRECEDING PARAMETER	----	0	0	0	0	0	0	0	0	0	0	7A-GEN.
SDEV	STANDARD DEVIATION OF PRECEDING PARAMETER	----	0	0	0	0	0	0	0	0	0	0	7A-GEN.
TEXT	PLAIN LANGUAGE TEXT	----	0	0	0	0	0	0	0	0	0	0	7A-GEN.
DATE	DATE WITHIN YEAR IN FORMAT MMDD	----	0	0	0	0	0	0	0	0	0	0	7B-DATE
HHMM	TIME WITHIN DAY IN FORMAT HHMM	----	0	0	0	0	0	0	0	0	0	0	7B-DATE
MNTH	CALENDAR MONTH (MM) WITHIN YEAR	----	0	0	0	0	0	0	0	0	0	0	7B-DATE
TIME	TIME WITHIN DAY IN FORMAT HHMMSS	----	0	0	0	0	0	0	0	0	0	0	7B-DATE
PSAL	PRACTICAL SALINITY	----	0	0	0	0	0	0	0	0	0	0	7E-OCEAN
SSPS	SEA SURFACE PRACTICAL SALINITY	----	0	0	0	0	0	0	0	0	0	0	7E-OCEAN
USAL	UNDEFINED SALINITY (Prac. Salin or parts/thousand) - see also SALD7AAN	----	0	0	0	0	0	0	0	0	0	0	7E-OCEAN
VBRF	WAVES SPECTRAL WIDTH (BROADNESS)	----	0	0	0	0	0	0	0	0	0	0	7F-WAVES
VSWD	WAVES SPECTRAL WIDTH FROM MOMENTS	----	0	0	0	0	0	0	0	0	0	0	7F-WAVES
CCVR	TOTAL CLOUD COVER IN TENTHS OF SKY	----	0	0	0	0	0	0	0	0	0	0	7G-MET.
SVCZ	BATHYMETRY SOUND VELOCITY CORRECTION AREA	----	0	0	0	0	0	0	0	0	0	0	7H-GEOPH.
PHPH	HYDROGEN ION CONCENTRATION (pH)	----	0	0	0	0	0	0	0	0	0	0	7I-CHEM.

PPPP	Parameter Name	Units	Dimension Exponents							CODE	Reference	
			MASS LNPTH	TIME TEMP	ELEC CHEM	LUM RADS	STER CNTS					
RELH	RELATIVE HUMIDITY	percent	0	0	0	0	0	0	0	0	0	7G-MET.
CHLR	CHLORINITY (PARTS/THOUSAND)	g/kg	0	0	0	0	0	0	0	0	0	7E-OCEAN
SSAL	SALINITY (PRE-1978 DEFINITION) (PARTS/THOUSAND)	g/kg	0	0	0	0	0	0	0	0	0	7E-OCEAN
SSSL	SEA SURFACE SALINITY (PRE-1978 DEFINITION) (PARTS/THOUSAND)	g/kg	0	0	0	0	0	0	0	0	0	7E-OCEAN
HMXR	HUMIDITY MIXING RATIO	g/kg	0	0	0	0	0	0	0	0	0	7G-MET.
SDHU	STANDARD DEVIATION OF SPECIFIC HUMIDITY	g/kg	0	0	0	0	0	0	0	0	0	7G-MET.
SPEH	SPECIFIC HUMIDITY	g/kg	0	0	0	0	0	0	0	0	0	7G-MET.
VRHU	VARIANCE OF SPECIFIC HUMIDITY	(g/kg)**2	0	0	0	0	0	0	0	0	0	7G-MET.
CCCC	DATA CYCLE OVERFLOW INDICATOR	code	0	0	0	0	0	0	0	0	1	7A-GEN.
CFLG	DATA CONTINUATION FLAG	code	0	0	0	0	0	0	0	0	1	7A-GEN.
FFFF	QUALITY CONTROL FLAG	code	0	0	0	0	0	0	0	0	1	7A-GEN.
GGQF	QUALITY CONTROL FLAGS FOR DATE, TIME, POSITION AND SEA FLOOR DEPTH	code	0	0	0	0	0	0	0	0	1	7A-GEN.
MMMM	METHOD CODE IN USER DEFINED AREA	code	0	0	0	0	0	0	0	0	1	7A-GEN.
PLAT	PLATFORM IDENTIFIER	code	0	0	0	0	0	0	0	0	1	7A-GEN.
QPOS	QUALITY CONTROL FLAG FOR GEOGRAPHIC POSITION	code	0	0	0	0	0	0	0	0	1	7A-GEN.
QTIM	QUALITY CONTROL FLAG FOR SERIES DATE/TIME	code	0	0	0	0	0	0	0	0	1	7A-GEN.
FIXF	PRIME NAVIGATION AID FIX FLAG	code	0	0	0	0	0	0	0	0	1	7D-POSN.
MMFX	METHOD CODE FOR POSITION FIXING	code	0	0	0	0	0	0	0	0	1	7D-POSN.
CAST	HYDROGRAPHIC CAST TYPE	code	0	0	0	0	0	0	0	0	1	7E-OCEAN
ICEF	FLAG FOR ICE IN VICINITY OF HYDROGRAPHIC OBSERVATIONS	code	0	0	0	0	0	0	0	0	1	7E-OCEAN
LVLS	SELECTION OF DEPTH LEVELS	code	0	0	0	0	0	0	0	0	1	7E-OCEAN
PRHB	PROBE HIT BOTTOM INDICATOR	code	0	0	0	0	0	0	0	0	1	7E-OCEAN
SALD	SALINITY UNITS FLAG	code	0	0	0	0	0	0	0	0	1	7E-OCEAN
TDFL	TRACE DIRECTION FLAG	code	0	0	0	0	0	0	0	0	1	7E-OCEAN
WCLR	WATER COLOUR (FOREL-ULE SCALE)	code	0	0	0	0	0	0	0	0	1	7E-OCEAN
SEAS	SEA STATE (WMO CODE 3700)	code	0	0	0	0	0	0	0	0	1	7F-WAVES
CHCH	TYPE OF HIGH ALTITUDE CLOUD (WMO CODE 0509)	code	0	0	0	0	0	0	0	0	1	7G-MET.
CLCL	TYPE OF LOW ALTITUDE CLOUD (WMO CODE 0513)	code	0	0	0	0	0	0	0	0	1	7G-MET.
CLCM	AMOUNT OF LOW/MEDIUM ALTITUDE CLOUD (OKTAS - WMO CODE 2700)	code	0	0	0	0	0	0	0	0	1	7G-MET.
CLDA	TOTAL CLOUD AMOUNT (OKTAS-WMO CODE 2700)	code	0	0	0	0	0	0	0	0	1	7G-MET.
CLDH	CLOUD BASE HEIGHT (WMO CODE 1600)	code	0	0	0	0	0	0	0	0	1	7G-MET.
CLDT	CLOUD TYPE (WMO CODE 0500)	code	0	0	0	0	0	0	0	0	1	7G-MET.
CMCM	TYPE OF MEDIUM ALTITUDE CLOUD (WMO CODE 0515)	code	0	0	0	0	0	0	0	0	1	7G-MET.
WFBS	WIND FORCE ON BEAUFORT SCALE	code	0	0	0	0	0	0	0	0	1	7G-MET.
WTHA	PAST WEATHER (WMO CODE 4561)	code	0	0	0	0	0	0	0	0	1	7G-MET.
WWCD	PRESENT WEATHER (WMO CODE 4677)	code	0	0	0	0	0	0	0	0	1	7G-MET.
DATM	BATHYMETRIC DATUM	code	0	0	0	0	0	0	0	0	1	7H-GEOPH.
CNQF	CHEMICAL CONTENT QUALIFIER FLAG	code	0	0	0	0	0	0	0	0	1	7I-CHEM.
GGCD	PERIOD OF CURRENT MEASUREMENT (DRIFT) (WMO CODE 2265)	code	0	0	0	0	0	0	0	0	1	7J-SPEC.
GGCM	INDICATOR FOR METHOD OF CURRENT MEASUREMENT (WMO CODE 2266)	code	0	0	0	0	0	0	0	0	1	7J-SPEC.

PPPP	Parameter Name	Units	Dimension Exponents										Reference		
			MASS LNTH	TIME	ELEC TEMP	LUM CHEM	STER RADS	CODE CNTS							
GGDI	INDICATOR FOR DIGITIZATION (WMO CODE 2262)	code	0	0	0	0	0	0	0	0	0	0	0	1	7J-SPEC.
GGEC	DURATION AND TIME OF EULERIAN CURRENT MEASUREMENT (WMO CODE 2264)	code	0	0	0	0	0	0	0	0	0	0	0	1	7J-SPEC.
GGIN	IGOSS BATHY/TEAC INDICATORS	code	0	0	0	0	0	0	0	0	0	0	0	1	7J-SPEC.
GGLC	QUALITY OF LOCATION (WMO CODE 3311)	code	0	0	0	0	0	0	0	0	0	0	0	1	7J-SPEC.
GGMS	IGOSS MESSAGE IDENTIFIER	code	0	0	0	0	0	0	0	0	0	0	0	1	7J-SPEC.
GGSL	METHOD OF SALINITY/DEPTH MEASUREMENT (WMO CODE 2263)	code	0	0	0	0	0	0	0	0	0	0	0	1	7J-SPEC.
GGST	QUALITY OF BUOY SATELLITE TRANSMISSION (WMO CODE 3313)	code	0	0	0	0	0	0	0	0	0	0	0	1	7J-SPEC.
GGWI	WIND SPEED INDICATOR (WMO CODE 1853)	code	0	0	0	0	0	0	0	0	0	0	0	1	7J-SPEC.
ATCK	ANGLE OF ATTACK (AIRCRAFT)	degrees	0	0	0	0	0	0	0	1	0	0	0	0	7D-POSN.
DIRM	BEARING OF OBJECT FROM REFERENCE POINT (relative to magnetic North)	degrees	0	0	0	0	0	0	0	1	0	0	0	0	7D-POSN.
DIRT	BEARING OF OBJECT FROM REFERENCE POINT (relative to True North)	degrees	0	0	0	0	0	0	0	1	0	0	0	0	7D-POSN.
EAZM	AZIMUTH OF MAJOR AXIS OF NAVIGATION ERROR ELLIPSE	degrees	0	0	0	0	0	0	0	1	0	0	0	0	7D-POSN.
ELEV	ELEVATION ANGLE OF OBJECT FROM REFERENCE POINT	degrees	0	0	0	0	0	0	0	1	0	0	0	0	7D-POSN.
HEAD	PLATFORM HEADING (relative to True North)	degrees	0	0	0	0	0	0	0	1	0	0	0	0	7D-POSN.
LATD	LATITUDE DEGREES (North +ve)	degrees	0	0	0	0	0	0	0	1	0	0	0	0	7D-POSN.
LOND	LONGITUDE DEGREES (East +ve)	degrees	0	0	0	0	0	0	0	1	0	0	0	0	7D-POSN.
MAGN	MAGNETIC VARIATION FROM TRUE NORTH	degrees	0	0	0	0	0	0	0	1	0	0	0	0	7D-POSN.
PTCH	PITCH ANGLE	degrees	0	0	0	0	0	0	0	1	0	0	0	0	7D-POSN.
ROLL	ROLL ANGLE	degrees	0	0	0	0	0	0	0	1	0	0	0	0	7D-POSN.
SIDE	ANGLE OF SIDESLIP (AIRCRAFT)	degrees	0	0	0	0	0	0	0	1	0	0	0	0	7D-POSN.
ZNTH	ZENITH ANGLE OF OBJECT FROM REFERENCE POINT	degrees	0	0	0	0	0	0	0	1	0	0	0	0	7D-POSN.
HCDM	DIRECTION TO WHICH HORIZONTAL CURRENT IS FLOWING (relative to Magnetic North)	degrees	0	0	0	0	0	0	0	1	0	0	0	0	7E-OCEAN
HCDT	DIRECTION TO WHICH HORIZONTAL CURRENT IS FLOWING (relative to True North)	degrees	0	0	0	0	0	0	0	1	0	0	0	0	7E-OCEAN
SCDT	DIRECTION TO WHICH SEA SURFACE CURRENT IS FLOWING (relative to True North)	degrees	0	0	0	0	0	0	0	1	0	0	0	0	7E-OCEAN
BDIR	BANDWIDTH OF DIRECTIONAL ANALYSIS	degrees	0	0	0	0	0	0	0	1	0	0	0	0	7F-WAVES
SWDR	DIRECTION FROM WHICH SWELL IS COMING (relative to True North)	degrees	0	0	0	0	0	0	0	1	0	0	0	0	7F-WAVES
VDEP	SPECIFIED DIRECTION OF WAVE ENERGY PROPAGATION	degrees	0	0	0	0	0	0	0	1	0	0	0	0	7F-WAVES
VDIR	VISUAL ESTIMATE OF DIRECTION FROM WHICH WAVES ARE COMING (relative to True North)	degrees	0	0	0	0	0	0	0	1	0	0	0	0	7F-WAVES
VMED	WAVE SPECTRUM MEAN ENERGY DIRECTION	degrees	0	0	0	0	0	0	0	1	0	0	0	0	7F-WAVES
VMWD	MEAN WAVE DIRECTION FROM CROSS SPECTRA	degrees	0	0	0	0	0	0	0	1	0	0	0	0	7F-WAVES
VPED	WAVE SPECTRUM PEAK ENERGY DIRECTION	degrees	0	0	0	0	0	0	0	1	0	0	0	0	7F-WAVES
VSPR	WAVE DIRECTIONAL SPREAD FROM CROSS SPECTRA	degrees	0	0	0	0	0	0	0	1	0	0	0	0	7F-WAVES
VNTE	WATER SURFACE EAST-WEST TILT ANGLE	degrees	0	0	0	0	0	0	0	1	0	0	0	0	7F-WAVES
VNTN	WATER SURFACE NORTH-SOUTH TILT ANGLE	degrees	0	0	0	0	0	0	0	1	0	0	0	0	7F-WAVES
GDIR	DIRECTION FROM WHICH GUST WIND IS BLOWING (relative to True North)	degrees	0	0	0	0	0	0	0	1	0	0	0	0	7G-MET.

PPPP	Parameter Name	Units	Dimension Exponents										Reference	
			MASS	TIME	ELEC	LUM	STER	CODE						
			LNPTH	TEMP	CHEM	RADS	CNTS							
WDIR	DIRECTION FROM WHICH WIND IS BLOWING (relative to True North)	degrees	0	0	0	0	0	0	0	1	0	0	0	7G-MET.
LATM	LATITUDE MINUTES WITHIN DEGREE (North +ve)	mins arc	0	0	0	0	0	0	0	1	0	0	0	7D-POSN.
LONM	LONGITUDE MINUTES WITHIN DEGREE (East +ve)	mins arc	0	0	0	0	0	0	0	1	0	0	0	7D-POSN.
POTM	POTENTIAL TEMPERATURE	degrees C	0	0	0	1	0	0	0	0	0	0	0	7E-OCEAN
SSTP	SEA SURFACE TEMPERATURE	degrees C	0	0	0	1	0	0	0	0	0	0	0	7E-OCEAN
TEMP	SEA TEMPERATURE	degrees C	0	0	0	1	0	0	0	0	0	0	0	7E-OCEAN
ASTD	AIR-SEA TEMPERATURE DIFFERENCE	degrees C	0	0	0	1	0	0	0	0	0	0	0	7G-MET.
BRIT	BRIGHTNESS (RADIATIVE) TEMPERATURE	degrees C	0	0	0	1	0	0	0	0	0	0	0	7G-MET.
DEWD	DEW POINT DEPRESSION	degrees C	0	0	0	1	0	0	0	0	0	0	0	7G-MET.
DEWT	DEW POINT TEMPERATURE	degrees C	0	0	0	1	0	0	0	0	0	0	0	7G-MET.
DRYT	DRY BULB TEMPERATURE	degrees C	0	0	0	1	0	0	0	0	0	0	0	7G-MET.
POTT	POTENTIAL AIR TEMPERATURE	degrees C	0	0	0	1	0	0	0	0	0	0	0	7G-MET.
SDAT	STANDARD DEVIATION OF AIR TEMPERATURE	degrees C	0	0	0	1	0	0	0	0	0	0	0	7G-MET.
SOLT	GROUND (SOIL) TEMPERATURE	degrees C	0	0	0	1	0	0	0	0	0	0	0	7G-MET.
STAG	STAGNATION TEMPERATURE	degrees C	0	0	0	1	0	0	0	0	0	0	0	7G-MET.
TDIF	AIR TEMPERATURE DIFFERENCE BETWEEN TWO LEVELS (UPPER-LOWER)	degrees C	0	0	0	1	0	0	0	0	0	0	0	7G-MET.
VIRT	VIRTUAL AIR TEMPERATURE	degrees C	0	0	0	1	0	0	0	0	0	0	0	7G-MET.
WETT	WET BULB TEMPERATURE	degrees C	0	0	0	1	0	0	0	0	0	0	0	7G-MET.
CVTQ	CO-VARIANCE OF AIR TEMPERATURE AND SPECIFIC HUMIDITY	degC.g/kg	0	0	0	1	0	0	0	0	0	0	0	7G-MET.
VRAT	VARIANCE OF AIR TEMPERATURE	degC**2	0	0	0	2	0	0	0	0	0	0	0	7G-MET.
YEAR	CALENDAR YEAR	years	0	0	1	0	0	0	0	0	0	0	0	7B-DATE
DAYS	DAY NUMBER WITHIN YEAR (Jan 1st = 1)	days	0	0	1	0	0	0	0	0	0	0	0	7B-DATE
HOUR	HOURS WITHIN DAY	hours	0	0	1	0	0	0	0	0	0	0	0	7B-DATE
ZONE	TIME ZONE CORRECTION	hours	0	0	1	0	0	0	0	0	0	0	0	7B-DATE
DRHR	DURATION (HOURS)	hours	0	0	1	0	0	0	0	0	0	0	0	7C-TIME
ETHR	ELAPSED TIME (HOURS)	hours	0	0	1	0	0	0	0	0	0	0	0	7C-TIME
NTHR	INTERVAL (HOURS)	hours	0	0	1	0	0	0	0	0	0	0	0	7C-TIME
MINS	MINUTES WITHIN HOUR	minutes	0	0	1	0	0	0	0	0	0	0	0	7B-DATE
DRMN	DURATION (MINUTES)	minutes	0	0	1	0	0	0	0	0	0	0	0	7C-TIME
ETMN	ELAPSED TIME (MINUTES)	minutes	0	0	1	0	0	0	0	0	0	0	0	7C-TIME
NTMN	INTERVAL (MINUTES)	minutes	0	0	1	0	0	0	0	0	0	0	0	7C-TIME
SECS	SECONDS WITHIN MINUTE	seconds	0	0	1	0	0	0	0	0	0	0	0	7B-DATE
DRSC	DURATION (SECONDS)	seconds	0	0	1	0	0	0	0	0	0	0	0	7C-TIME
ETSC	ELAPSED TIME (SECONDS)	seconds	0	0	1	0	0	0	0	0	0	0	0	7C-TIME
NTSC	INTERVAL (SECONDS)	seconds	0	0	1	0	0	0	0	0	0	0	0	7C-TIME
SWPR	SWELL PERIOD	seconds	0	0	1	0	0	0	0	0	0	0	0	7F-WAVES
VPER	VISUAL ESTIMATE OF WAVE PERIOD	seconds	0	0	1	0	0	0	0	0	0	0	0	7F-WAVES
VSMA	SPECTRAL MOMENTS (-1,0) WAVE PERIOD	seconds	0	0	1	0	0	0	0	0	0	0	0	7F-WAVES
VSMB	SPECTRAL MOMENTS (0,1) WAVE PERIOD	seconds	0	0	1	0	0	0	0	0	0	0	0	7F-WAVES
VSMC	SPECTRAL MOMENTS (0,2) WAVE PERIOD	seconds	0	0	1	0	0	0	0	0	0	0	0	7F-WAVES
VSMO	SPECTRAL MOMENTS (2,4) WAVE PERIOD	seconds	0	0	1	0	0	0	0	0	0	0	0	7F-WAVES
VTCA	AVERAGE WAVE CREST PERIOD	seconds	0	0	1	0	0	0	0	0	0	0	0	7F-WAVES
VTPK	WAVE SPECTRUM PEAK PERIOD	seconds	0	0	1	0	0	0	0	0	0	0	0	7F-WAVES
VTZA	AVERAGE ZERO CROSSING WAVE PERIOD	seconds	0	0	1	0	0	0	0	0	0	0	0	7F-WAVES

PPPP	Parameter Name	Units	Dimension-Exponents										Reference
			MASS	TIME	ELEC	LUM	STER	CODE					
			LNTH	TEMP	CHEM	RADS	CNTS						
VTZM	PERIOD OF MAXIMUM ZERO CROSSING WAVE	seconds	0	0	1	0	0	0	0	0	0	0	7F-WAVES
TWTT	BATHYMETRIC TWO WAY TRAVEL TIME	seconds	0	0	1	0	0	0	0	0	0	0	7H-GEOPH.
VCXX	AUTO-SPECTRUM OF NORTH-SOUTH TILT	deg**2/Hz	0	0	1	0	0	0	0	2	0	0	7F-WAVES
VCXY	CO-SPECTRUM OF NORTH-SOUTH AND EAST-WEST TILTS	deg**2/Hz	0	0	1	0	0	0	0	2	0	0	7F-WAVES
VCYY	AUTO-SPECTRUM OF EAST-WEST TILT	deg**2/Hz	0	0	1	0	0	0	0	2	0	0	7F-WAVES
VQXY	QUAD-SPECTRUM OF NORTH-SOUTH AND EAST-WEST TILTS	deg**2/Hz	0	0	1	0	0	0	0	2	0	0	7F-WAVES
GBGA	BOUGER GRAVITY ANOMALY	milligals	0	1	-2	0	0	0	0	0	0	0	7H-GEOPH.
GEOT	GRAVITY EOTVOS CORRECTION	milligals	0	1	-2	0	0	0	0	0	0	0	7H-GEOPH.
GFAA	FREE AIR GRAVITY ANOMALY	milligals	0	1	-2	0	0	0	0	0	0	0	7H-GEOPH.
GRAV	OBSERVED GRAVITY	milligals	0	1	-2	0	0	0	0	0	0	0	7H-GEOPH.
VWSA	INSTANTANEOUS HEAVE ACCELERATION	m/s**2	0	1	-2	0	0	0	0	0	0	0	7F-WAVES
SPDG	TRUE PLATFORM SPEED ACROSS THE GROUND	m/s	0	1	-1	0	0	0	0	0	0	0	7D-POSN.
SPDI	INDICATED PLATFORM SPEED (AIRCRAFT)	m/s	0	1	-1	0	0	0	0	0	0	0	7D-POSN.
SPDR	RELATIVE PLATFORM SPEED THROUGH THE AIR/WATER	m/s	0	1	-1	0	0	0	0	0	0	0	7D-POSN.
SPOV	VERTICAL PLATFORM SPEED	m/s	0	1	-1	0	0	0	0	0	0	0	7D-POSN.
EWCM	EAST (MAGNETIC) COMPONENT OF CURRENT	m/s	0	1	-1	0	0	0	0	0	0	0	7E-OCEAN
EWCT	EAST (TRUE) COMPONENT OF CURRENT	m/s	0	1	-1	0	0	0	0	0	0	0	7E-OCEAN
HCSP	HORIZONTAL CURRENT SPEED	m/s	0	1	-1	0	0	0	0	0	0	0	7E-OCEAN
NSCM	NORTH (MAGNETIC) COMPONENT OF CURRENT	m/s	0	1	-1	0	0	0	0	0	0	0	7E-OCEAN
NSCT	NORTH (TRUE) COMPONENT OF CURRENT	m/s	0	1	-1	0	0	0	0	0	0	0	7E-OCEAN
SCSP	SEA SURFACE CURRENT SPEED	m/s	0	1	-1	0	0	0	0	0	0	0	7E-OCEAN
SVEL	SOUND VELOCITY	m/s	0	1	-1	0	0	0	0	0	0	0	7E-OCEAN
GSPD	GUST WIND SPEED	m/s	0	1	-1	0	0	0	0	0	0	0	7G-MET.
SDWS	STANDARD DEVIATION OF WIND SPEED	m/s	0	1	-1	0	0	0	0	0	0	0	7G-MET.
WSPD	HORIZONTAL WIND SPEED	m/s	0	1	-1	0	0	0	0	0	0	0	7G-MET.
WSPE	EASTWARD (TRUE) COMPONENT OF WIND SPEED	m/s	0	1	-1	0	0	0	0	0	0	0	7G-MET.
WSPN	NORTHWARD (TRUE) COMPONENT OF WIND SPEED	m/s	0	1	-1	0	0	0	0	0	0	0	7G-MET.
WVER	VERTICAL WIND SPEED	m/s	0	1	-1	0	0	0	0	0	0	0	7G-MET.
PRRT	PRECIPITATION RATE	mm/hr	0	1	-1	0	0	0	0	0	0	0	7G-MET.
CVWQ	CO-VARIANCE OF WIND SPEED AND SPECIFIC HUMIDITY	(m/s).g/kg	0	1	-1	0	0	0	0	0	0	0	7G-MET.
CVWT	CO-VARIANCE OF WIND SPEED AND AIR TEMPERATURE	degC.m/s	0	1	-1	1	0	0	0	0	0	0	7G-MET.
ALTG	HEIGHT/ALTITUDE ABOVE GROUND LEVEL	metres	0	1	0	0	0	0	0	0	0	0	7D-POSN.
ALTS	HEIGHT/ALTITUDE ABOVE MEAN SEA LEVEL	metres	0	1	0	0	0	0	0	0	0	0	7D-POSN.
ATRK	ALONG TRACK DISPLACEMENT	metres	0	1	0	0	0	0	0	0	0	0	7D-POSN.
DEPH	SENSOR DEPTH BELOW SEA SURFACE	metres	0	1	0	0	0	0	0	0	0	0	7D-POSN.
DISE	DISTANCE OF OBJECT IN DIRECTION TRUE EAST FROM REFERENCE POINT	metres	0	1	0	0	0	0	0	0	0	0	7D-POSN.
DISN	DISTANCE OF OBJECT IN DIRECTION TRUE NORTH FROM REFERENCE POINT	metres	0	1	0	0	0	0	0	0	0	0	7D-POSN.
DPSF	DEPTH BELOW SEA FLOOR	metres	0	1	0	0	0	0	0	0	0	0	7D-POSN.
EMAJ	LENGTH OF SEMIMAJOR AXIS OF NAVIGATION ERROR ELLIPSE	metres	0	1	0	0	0	0	0	0	0	0	7D-POSN.
EMIN	LENGTH OF SEMIMINOR AXIS OF NAVIGATION ERROR ELLIPSE	metres	0	1	0	0	0	0	0	0	0	0	7D-POSN.
HGHT	HEIGHT/ALTITUDE ABOVE SEA SURFACE	metres	0	1	0	0	0	0	0	0	0	0	7D-POSN.
HTSF	HEIGHT ABOVE SEA FLOOR	metres	0	1	0	0	0	0	0	0	0	0	7D-POSN.

PPPP	Parameter Name	Units	Dimension Exponents										Reference	
			MASS	TIME	ELEC	LUM	STER	CODE						
			LNPTH	TEMP	CHEM	RADS	CNTS							
RADD	HORIZONTAL DISTANCE OF OBJECT FROM REFERENCE POINT	metres	0	1	0	0	0	0	0	0	0	0	0	7D-POSN.
RANG	DIRECT DISTANCE OF OBJECT FROM REFERENCE POINT	metres	0	1	0	0	0	0	0	0	0	0	0	7D-POSN.
VERT	VERTICAL DISTANCE OF OBJECT ABOVE REFERENCE POINT	metres	0	1	0	0	0	0	0	0	0	0	0	7D-POSN.
XTRK	ACROSS TRACK DISPLACEMENT (starboard +ve)	metres	0	1	0	0	0	0	0	0	0	0	0	7D-POSN.
DRDP	DEPTH OF DROGUE	metres	0	1	0	0	0	0	0	0	0	0	0	7E-OCEAN
SECC	SECCHI DISC DEPTH	metres	0	1	0	0	0	0	0	0	0	0	0	7E-OCEAN
SLEV	OBSERVED SEA LEVEL	metres	0	1	0	0	0	0	0	0	0	0	0	7E-OCEAN
SWHT	SWELL HEIGHT	metres	0	1	0	0	0	0	0	0	0	0	0	7F-WAVES
VAVH	AVERAGE HEIGHT HIGHEST ONE THIRD WAVES	metres	0	1	0	0	0	0	0	0	0	0	0	7F-WAVES
VCAR	CHARACTERISTIC WAVE HEIGHT (4*RMS)	metres	0	1	0	0	0	0	0	0	0	0	0	7F-WAVES
VCMX	MAXIMUM CREST TO TROUGH WAVE HEIGHT	metres	0	1	0	0	0	0	0	0	0	0	0	7F-WAVES
VEST	VISUAL AVERAGE WAVE HEIGHT	metres	0	1	0	0	0	0	0	0	0	0	0	7F-WAVES
VMNL	MINIMUM WAVE LEVEL	metres	0	1	0	0	0	0	0	0	0	0	0	7F-WAVES
VMXL	MAXIMUM WAVE LEVEL	metres	0	1	0	0	0	0	0	0	0	0	0	7F-WAVES
VRMS	RMS WAVE DISPLACEMENT	metres	0	1	0	0	0	0	0	0	0	0	0	7F-WAVES
VTDH	TUCKER DRAPER SIGNIFICANT WAVE HEIGHT	metres	0	1	0	0	0	0	0	0	0	0	0	7F-WAVES
VTKC	SECOND HIGHEST WAVE CREST	metres	0	1	0	0	0	0	0	0	0	0	0	7F-WAVES
VTKD	SECOND LOWEST WAVE TROUGH	metres	0	1	0	0	0	0	0	0	0	0	0	7F-WAVES
VWSE	INSTANTANEOUS WATER SURFACE ELEVATION	metres	0	1	0	0	0	0	0	0	0	0	0	7F-WAVES
VZMX	MAXIMUM ZERO CROSSING WAVE HEIGHT	metres	0	1	0	0	0	0	0	0	0	0	0	7F-WAVES
WMDP	MEAN WATER DEPTH	metres	0	1	0	0	0	0	0	0	0	0	0	7F-WAVES
WRDP	MEAN RECORD WATER DEPTH	metres	0	1	0	0	0	0	0	0	0	0	0	7F-WAVES
WSDP	STILL WATER DEPTH	metres	0	1	0	0	0	0	0	0	0	0	0	7F-WAVES
CLOB	CLOUD BASE ALTITUDE	metres	0	1	0	0	0	0	0	0	0	0	0	7G-MET.
VISB	HORIZONTAL VISIBILITY	metres	0	1	0	0	0	0	0	0	0	0	0	7G-MET.
BATH	BATHYMETRIC DEPTH	metres	0	1	0	0	0	0	0	0	0	0	0	7H-GEOPH.
PRTN	PRECIPITATION AMOUNT	mm	0	1	0	0	0	0	0	0	0	0	0	7G-MET.
VCZX	CO-SPECTRUM OF HEAVE AND NORTH-SOUTH TILT	m.deg/Hz	0	1	1	0	0	0	0	1	0	0	0	7F-WAVES
VCZY	CO-SPECTRUM OF HEAVE AND EAST-WEST TILT	m.deg/Hz	0	1	1	0	0	0	0	1	0	0	0	7F-WAVES
VQZX	QUAD-SPECTRUM OF HEAVE AND NORTH-SOUTH TILT	m.deg/Hz	0	1	1	0	0	0	0	1	0	0	0	7F-WAVES
VQZY	QUAD-SPECTRUM OF HEAVE AND EAST-WEST TILT	m.deg/Hz	0	1	1	0	0	0	0	1	0	0	0	7F-WAVES
VMTE	FOURTH MOMENT OF WAVE SPECTRUM	m**2.Hz**4	0	2	-4	0	0	0	0	0	0	0	0	7F-WAVES
VMTD	THIRD MOMENT OF WAVE SPECTRUM	m**2.Hz**3	0	2	-3	0	0	0	0	0	0	0	0	7F-WAVES
VMTC	SECOND MOMENT OF WAVE SPECTRUM	(m.Hz)**2	0	2	-2	0	0	0	0	0	0	0	0	7F-WAVES
CVNS	CO-VARIANCE OF WIND SPEED COMPONENTS	(m/s)**2	0	2	-2	0	0	0	0	0	0	0	0	7G-MET.
VRWS	VARIANCE OF WIND SPEED	(m/s)**2	0	2	-2	0	0	0	0	0	0	0	0	7G-MET.
VMTB	FIRST MOMENT OF WAVE SPECTRUM	m**2.Hz	0	2	-1	0	0	0	0	0	0	0	0	7F-WAVES
VWSH	VERTICAL WIND SHEAR	(m/s)/km	0	2	-1	0	0	0	0	0	0	0	0	7G-MET.
VMTA	ZEROETH MOMENT OF WAVE SPECTRUM	m**2	0	2	0	0	0	0	0	0	0	0	0	7F-WAVES
VDSO	DIRECTIONAL WAVE SPECTRUM DENSITY	m**2/Hz	0	2	1	0	0	0	0	0	0	0	0	7F-WAVES
VMTM	FIRST NEGATIVE MOMENT OF WAVE SPECTRUM	m**2/Hz	0	2	1	0	0	0	0	0	0	0	0	7F-WAVES
VSDN	WAVE VARIANCE SPECTRAL DENSITY : S(f)	m**2/Hz	0	2	1	0	0	0	0	0	0	0	0	7F-WAVES
VMTN	SECOND NEGATIVE MOMENT OF WAVE SPECTRUM	(m/Hz)**2	0	2	2	0	0	0	0	0	0	0	0	7F-WAVES

PPPP	Parameter Name	Units	Dimension Exponents										Reference
			MASS	TIME	ELEC	LUM	STER	CODE	Reference				
			LNTH	TEMP	CHEM	RADS	CNTS						
CHLS	CHLOROSITY	kg/m**3	1	-3	0	0	0	0	0	0	0	0	7E-OCEAN
DENS	SEA DENSITY	kg/m**3	1	-3	0	0	0	0	0	0	0	0	7E-OCEAN
ABSH	ABSOLUTE HUMIDITY	g/m**3	1	-3	0	0	0	0	0	0	0	0	7G-MET.
LWCT	LIQUID WATER CONTENT	g/m**3	1	-3	0	0	0	0	0	0	0	0	7G-MET.
TWCT	TOTAL WATER CONTENT	g/m**3	1	-3	0	0	0	0	0	0	0	0	7G-MET.
CPHL	CHLOROPHYLL-A CONTENT	mg/m**3	1	-3	0	0	0	0	0	0	0	0	7I-CHEM.
ATPT	ATMOSPHERIC PRESSURE TENDENCY	hPa/hr	1	-1	-3	0	0	0	0	0	0	0	7G-MET.
PRES	SEA PRESSURE (sea surface = 0)	decibars	1	-1	-2	0	0	0	0	0	0	0	7E-OCEAN
RELP	RELATIVE TOTAL PRESSURE	decibars	1	-1	-2	0	0	0	0	0	0	0	7E-OCEAN
TOTP	TOTAL PRESSURE (atmosphere+sea pressure)	decibars	1	-1	-2	0	0	0	0	0	0	0	7E-OCEAN
ATMP	ATMOSPHERIC PRESSURE AT ALTITUDE	hPa	1	-1	-2	0	0	0	0	0	0	0	7G-MET.
ATMS	ATMOSPHERIC PRESSURE AT SEA LEVEL	hPa	1	-1	-2	0	0	0	0	0	0	0	7G-MET.
VAPP	ACTUAL WATER VAPOUR PRESSURE	hPa	1	-1	-2	0	0	0	0	0	0	0	7G-MET.
LINC	LONG-WAVE INCOMING RADIATION	W/m**2	1	0	-3	0	0	0	0	0	0	0	7G-MET.
LOUT	LONG-WAVE OUTGOING RADIATION	W/m**2	1	0	-3	0	0	0	0	0	0	0	7G-MET.
NETR	NET RADIATION	W/m**2	1	0	-3	0	0	0	0	0	0	0	7G-MET.
NIRR	NEAR-INFRARED RADIATION	W/m**2	1	0	-3	0	0	0	0	0	0	0	7G-MET.
QSOL	GROUND HEAT FLUX	W/m**2	1	0	-3	0	0	0	0	0	0	0	7G-MET.
SDIF	SHORT-WAVE DIFFUSE RADIATION	W/m**2	1	0	-3	0	0	0	0	0	0	0	7G-MET.
SDIR	SHORT-WAVE DIRECT RADIATION	W/m**2	1	0	-3	0	0	0	0	0	0	0	7G-MET.
SINC	SHORT-WAVE INCOMING RADIATION	W/m**2	1	0	-3	0	0	0	0	0	0	0	7G-MET.
SOUT	SHORT-WAVE OUTGOING RADIATION	W/m**2	1	0	-3	0	0	0	0	0	0	0	7G-MET.
ULTR	ULTRA-VIOLET RADIATION	W/m**2	1	0	-3	0	0	0	0	0	0	0	7G-MET.
MAGC	MAGNETIC FIELD CORRECTION	nanoteslas	1	0	-2	0	-1	0	0	0	0	0	7H-GEOPH.
MAGR	RESIDUAL MAGNETIC FIELD	nanoteslas	1	0	-2	0	-1	0	0	0	0	0	7H-GEOPH.
MAGT	TOTAL MAGNETIC FIELD	nanoteslas	1	0	-2	0	-1	0	0	0	0	0	7H-GEOPH.

ANNEX X

WMO CODE TABLES

This Annex contains a selection of code tables from the 1984 edition (updated January 1986) of Volume I of the World Meteorological Organization Manual on Codes (WMO - No. 306). The selection covers those WMO Code Tables which have been assigned a standard GF3 parameter code thus:

WMO Code Table	GF3 Parameter Code	
0500	CLDT7XXA	CLOUD TYPE
0509	CHCH7XXA	TYPE OF HIGH ALTITUDE CLOUD
0513	CLCL7XXA	TYPE OF LOW ALTITUDE CLOUD
0515	CMCM7XXA	TYPE OF MEDIUM ALTITUDE CLOUD
1600	CLDH7XXA	HEIGHT OF CLOUD BASE
1853	GGWI7XXN	INDICATOR FOR UNITS OF WIND SPEED AND TYPE OF INSTRUMENTATION
2262	GGDI7XXN	INDICATOR FOR DIGITIZATION
2263	GGSL7XXN	METHOD OF SALINITY/DEPTH MEASUREMENT
2264	GGEC7XXN	DURATION AND TIME OF CURRENT MEASUREMENT (EULERIAN)
2265	GGCD7XXN	PERIOD OF CURRENT MEASUREMENT (DRIFT METHOD)
2266	GGCM7XXN	INDICATOR FOR METHOD OF CURRENT MEASUREMENT
2700	CLDA7XXA CLCM7XXA	CLOUD COVER IN OKTAS OF SKY
3311	GGLC7XXN	QUALITY OF LOCATION
3313	GGST7XXN	QUALITY OF BUOY SATELLITE TRANSMISSION
3700	SEAS7XXD	STATE OF SEA
4561	WTHA7XXA	PAST WEATHER
4677	WWCD7XXA	PRESENT WEATHER

WMO CODE TABLE 0500

CLOUD TYPE

(GF3 parameter CLDT7XXA - Table 7G)

Code figure	Code figure
0 Cirrus	5 Nimbostratus
1 Cirrocumulus	6 Stratocumulus
2 Cirrostratus	7 Stratus
3 Altopcumulus	8 Cumulus
4 Altostratus	9 Cumulonimbus
/ Cloud not visible owing to darkness, fog, duststorm, sandstorm, or other analogous phenomena	

WMO CODE TABLE 0509

TYPE OF HIGH ALTITUDE CLOUD

Clouds of genera Cirrus, Cirrocumulus and Cirrostratus

(GF3 parameter CHCH7XXA - Table 7G)

Code figure	Description
0	No Cirrus, Cirrocumulus or Cirrostratus
1	Cirrus in the form of filaments (i.e. Cirrus fibratus), or hooks (i.e. Cirrus uncinus), not progressively invading the sky
2	Dense Cirrus (i.e. Cirrus spissatus), in patches or entangled sheaves, which usually do not increase and sometimes seem to be the remains of the upper part of a Cumulonimbus; or Cirrus with sproutings in the form of small turrets or battlements (i.e. Cirrus castellanus); or Cirrus having the appearance of cumuliform tufts (i.e. Cirrus floccus)
3	Dense Cirrus, often in the form of an anvil, being the remains of the upper parts of Cumulonimbus (i.e. Cirrus spissatus cumulonimbogenitus)
4	Cirrus uncinus or fibratus, or both, progressively invading the sky; they generally thicken as a whole
5	Cirrus (often in bands converging towards one point or two opposite points of the horizon) and Cirrostratus, or Cirrostratus alone; in either case, they are progressively invading the sky, and generally growing denser as a whole, but the continuous veil does not reach 45 degrees above the horizon
6	Cirrus (often in bands converging towards one point or two opposite points of the horizon) and Cirrostratus, or Cirrostratus alone; in either case, they are progressively invading the sky, and generally growing denser as a whole; the continuous veil extends more than 45 degrees above the horizon, without the sky being totally covered
7	Veil of Cirrostratus covering the celestial dome
8	Cirrostratus not progressively invading the sky and not completely covering the celestial dome
9	Cirrocumulus alone, or Cirrocumulus accompanied by Cirrus or Cirrostratus, or both, but Cirrocumulus is predominant
/	Cirrus, Cirrocumulus and Cirrostratus invisible owing to darkness, fog, blowing dust or sand, or other similar phenomena, or more often because of the presence of a continuous layer of lower clouds

WMO CODE TABLE 0513

TYPE OF LOW ALTITUDE CLOUD

Clouds of genera Stratocumulus, Stratus, Cumulus and Cumulonimbus

(GF3 parameter CLCL7XXA - Table 7G)

Code figure	Description
0	No Stratocumulus, Stratus, Cumulus or Cumulonimbus
1	Cumulus with little vertical extent and seemingly flattened (i.e. Cumulus humilis), or ragged Cumulus (i.e. Cumulus fractus) other than of bad weather*, or both

Code figure

2	Cumulus of moderate (Cumulus mediocris) or strong (Cumulus congestus) vertical extent, generally with protuberances in the form of domes or towers, either accompanied or not by other Cumulus or by Stratocumulus, all having their bases at the same level
3	(Cumulonimbus calvus) Cumulonimbus the summits of which, at least partially, lack sharp outlines, but are neither clearly fibrous (cirriform) nor in the form of an anvil; Cumulus, Stratocumulus or Stratus may also be present
4	Stratocumulus formed by the spreading out of Cumulus (i.e. Stratocumulus cumulogenitus); Cumulus may also be present
5	Stratocumulus other than Stratocumulus cumulogenitus
6	Stratus in a more or less continuous sheet or layer (i.e. Stratus nebulosus), or in ragged shreds (i.e. Stratus fractus), or both, but no Stratus fractus of bad weather*
7	Stratus fractus of bad weather* or Cumulus fractus of bad weather, or both (pannus), usually below Altostratus or Nimbostratus
8	Cumulus and Stratocumulus other than Stratocumulus cumulogenitus; the base of the Cumulus is at a different level from that of the Stratocumulus
9	(Cumulonimbus capillatus) Cumulonimbus, the upper part of which is clearly fibrous (cirriform), often in the form of an anvil; either accompanied or not by Cumulonimbus calvus, by Cumulus, Stratocumulus, Stratus or pannus
/	Stratocumulus, Stratus, Cumulus and Cumulonimbus invisible owing to darkness, fog, blowing dust or sand, or other similar phenomena

* "Bad weather" denotes the conditions which generally exist during precipitation and a short time before and after.

WMO CODE TABLE 0515

TYPE OF MEDIUM ALTITUDE CLOUD

Clouds of genera Altopcumulus, Altostratus and Nimbostratus

(GF3 parameter CMCM7XXA - Table 7G)

Code figure

Code figure	Description
0	No Altopcumulus, Altostratus or Nimbostratus
1	Altostratus, the greater part of which is semi-transparent (i.e. Altostratus translucidus); through this part the sun or moon may be weakly visible, as through ground glass
2	Altostratus, the greater part of which is sufficiently dense to hide the sun or moon (i.e. Altostratus opacus), or Nimbostratus
3	Altostratus translucidus at a single level and the elements of the cloud change only slowly
4	Patches (often lenticular) of Altopcumulus translucidus; the clouds occur at one or more levels and the elements are continually changing in appearance
5	Altopcumulus translucidus in bands, or one or more layers of Altopcumulus translucidus or opacus, progressively invading the sky; these Altopcumulus clouds generally thicken as a whole
6	Altopcumulus resulting from the spreading out of Cumulus (or Cumulonimbus) - i.e. Altopcumulus cumulogenitus (or cumulonimbogenitus)
7	Altopcumulus translucidus or opacus in two or more layers, or Altopcumulus opacus in a single layer, not progressively invading the sky, or Altopcumulus with Altostratus or Nimbostratus
8	Altopcumulus with sproutings in the form of small towers or battlements (i.e. Altopcumulus castellanus), or Altopcumulus having the appearance of cumuliform tufts (i.e. Altopcumulus floccus)
9	Altopcumulus of a chaotic sky, generally at several levels
/	Altopcumulus, Altostratus and Nimbostratus invisible owing to darkness, fog, blowing dust or sand, or other similar phenomena, or more often because of the presence of a continuous layer of lower clouds

WMO CODE TABLE 1600

HEIGHT OF CLOUD BASE

(GF3 parameter CLDH7XXA - Table 7G)

Code figure	Code figure
0 0 TO 50m	5 600 to 1000m
1 50 to 100m	6 1000 to 1500m
2 100 to 200m	7 1500 to 2000m
3 200 to 300m	8 2000 to 2500m
4 300 to 600m	9 2500m or more, or no clouds
/ Height of base of cloud not known or base of clouds at a level lower and tops at a level higher than that of the station	

Notes:

- (1) A height exactly equal to one of the values at the ends of the ranges shall be coded in the higher range, e.g. a height of 600m shall be reported by code figure 5.
- (2) Due to the limitation in range of the cloud-sensing equipment used by an automatic station, the code figures reported could have one of the three following meanings:
 - (a) The actual height of the base of the cloud is within the range indicated by the code figure; or
 - (b) The height of the base of the cloud is greater than the range indicated by the code figure but cannot be determined due to instrumental limitations; or
 - (c) There are no clouds vertically above the station.

WMO CODE TABLE 1853

i_w: INDICATOR FOR UNITS OF WIND SPEED AND TYPE OF INSTRUMENTATION

(GF3 parameter GGI7XXN - Table 7J)

Code figure	certified instruments:
0	m/sec
1	knots
uncertified instruments:	
2	m/sec
3	knots

N.B. Code does not necessarily relate to the units in which wind speed is subsequently stored.

WMO CODE TABLE 2262

k₁: INDICATOR FOR DIGITIZATION

(GF3 parameter GGD7XXN - Table 7J)

Code figure	
7	Values at selected depths (data points fixed by the instrument or selected by any other method)
8	Values at significant depths (data points taken from traces at significant depths)

WMO CODE TABLE 2263

k₂: METHOD OF SALINITY/DEPTH MEASUREMENT

(GF3 parameter GGSL7XXN - Table 7J)

Code figure	
0	No salinity measured
1	In situ sensor, accuracy better than 0.02 pts/thousand
2	In situ sensor, accuracy less than 0.02 pts/thousand
3	Sample analysis

WMO CODE TABLE 2264

k₃: DURATION AND TIME OF CURRENT MEASUREMENT (VECTOR OR DOPPLER CURRENT PROFILING METHOD)

(GF3 parameter GGEC7XXN - Table 7J)

Code figure	
Between H-1 and H	
1	Instantaneous
2	Averaged over 3 minutes or less
3	Averaged over more than 3 minutes, but 6 at the most
4	Averaged over more than 6 minutes, but 12 at the most
Between H-2 and H-1	
5	Instantaneous
6	Averaged over 3 minutes or less
7	Averaged over more than 3 minutes, but 6 at the most
8	Averaged over more than 6 minutes, but 12 at the most
9	Vector or Doppler current profiling method not used

Note: H = Time of observation. When Doppler current profiling method is used, codes 1 through 4 are used

WMO CODE TABLE 2265

k₄: PERIOD OF CURRENT MEASUREMENT (DRIFT METHOD)

(GF3 parameter GGCD7XXN - Table 7J)

Code figure	
1	1 hour or less
2	More than 1 hour but 2 at the most
3	More than 2 hours but 4 at the most
4	More than 4 hours but 8 at the most
5	More than 8 hours but 12 at the most
6	More than 12 hours but 18 at the most
7	More than 18 hours but 24 at the most
9	Drift method not used

WMO CODE TABLE 2266

k₅: INDICATOR FOR THE METHOD OF CURRENT MEASUREMENT

(GF3 parameter GGCM7XXN - Table 7J)

Code figure	
2	GEK (Geomagnetic Electrokinetograph)
3	Ship's set and drift determined by fixes 3-6 hours apart
4	Ship's set and drift determined by fixes more than 6 hours but less than 12 hours apart

WMO CODE TABLE 2700

CLOUD COVER IN OKTAS OF SKY

(GF3 parameter CLDA7XXA or CLCM7XXA - Table 7G)

Code figure		
0	0	0
1	1 okta or less, but not zero	0.1 or less, but not zero
2	2 oktas	0.2 - 0.3
3	3 oktas	0.4
4	4 oktas	0.5
5	5 oktas	0.6
6	6 oktas	0.7 - 0.8
7	7 oktas or more, but not 8	0.9 or more, but not 1.0
8	8 oktas	1.0
9	Sky obscured, or cloud amount cannot be estimated	

WMO CODE TABLE 3311

QL: QUALITY OF LOCATION
(GF3 parameter GGLC7XXN - Table 7J)

Code figure	
0	The value transmitted at the beginning of the message is a reliable value (location made over two satellite passes)
1	The values at the beginning of the message are the latest known values (no location over the corresponding pass)
2	Dubious quality. The location was made over one pass only; a second solution is possible in 5% of the cases

WMO CODE TABLE 3313

QW: QUALITY OF THE BUOY SATELLITE TRANSMISSION
(GF3 parameter GGST7XXN - Table 7J)

Code figure	
0	Good quality (several identical messages have been received)
1	Dubious quality (no identical messages)

WMO CODE TABLE 3700

STATE OF SEA
(GF3 parameter SEAS7XXD - Table 7F)

Code figure	Descriptive terms	Height* in metres
0	Calm (glassy)	0
1	Calm (rippled)	0 - 0.1
2	Smooth (wavelets)	0.1 - 0.5
3	Slight	0.5 - 1.25
4	Moderate	1.25 - 2.5
5	Rough	2.5 - 4
6	Very rough	4 - 6
7	High	6 - 9
8	Very high	9 - 14
9	Phenomenal	Over 14

Notes:

- (1) *These values refer to well-developed wind waves of the open sea. While priority shall be given to the descriptive terms, these height values may be used for guidance by the observer when reporting the total state of agitation of the sea resulting from various factors such as wind, swell, currents, angle between swell and wind, etc.
- (2) The exact bounding height shall be assigned for the lower code figure; e.g. a height of 4m is coded as 5.

WMO CODE TABLE 4561

PAST WEATHER
(GF3 parameter WTHA7XXA - Table 7G)

Code figure	
0	Cloud covering half or less of the sky throughout the appropriate period
1	Cloud covering more than half of the sky during part of the appropriate period and covering half or less during part of the period
2	Cloud covering more than half of the sky throughout the appropriate period
3	Sandstorm, duststorm or blowing snow
4	Fog or ice fog or thick haze
5	Drizzle
6	Rain
7	Snow, or rain and snow mixed
8	Shower(s)
9	Thunderstorm(s) with or without precipitation

WMO CODE TABLE 4677

PRESENT WEATHER
(GF3 parameter WWC07XXA - Table 7G)

Summary

00-49	<u>No precipitation at the station at the time of observation</u>
00-19	No precipitation, fog, ice fog (except for 11 and 12), duststorm, sandstorm, drifting or blowing snow at the station at the time of observation or, except for 09 and 17, during the preceding hour
20-29	Precipitation, fog, ice fog or thunderstorm at the station during the preceding hour but not at the time of observation
30-39	Duststorm, sandstorm, drifting or blowing snow
40-49	Fog or ice fog at the time of observation
50-99	<u>Precipitation at the station at the time of observation</u>
50-59	Drizzle
60-69	Rain
70-79	Solid precipitation not in showers
80-99	Showery precipitation, or precipitation with current or recent thunderstorm

Detailed Coding

Code figure		
00	Cloud development not observed or not observable	} characteristic change of the state of sky during the past hour
01	Clouds generally dissolving or becoming less developed	
02	State of sky on the whole unchanged	
03	Clouds generally forming or developing	
04	Visibility reduced by smoke, e.g. veidt or forest fires, industrial smoke or volcanic ashes	
05	Haze	
06	Widespread dust in suspension in the air, not raised by wind at or near the station at the time of observation	
07	Dust or sand raised by wind at or near the station at the time of observation, but no well-developed dust whirl(s) or sand whirl(s), and no duststorm or sandstorm seen; or, in the case of ships, blowing spray at the station	
08	Well-developed dust whirl(s) or sand whirl(s) seen at or near the station during the preceding hour or at the time of observation, but no duststorm or sandstorm	
09	Duststorm or sandstorm within sight at the time of observation, or at the station during the preceding hour	
10	Mist	
11	Patches	} shallow fog or ice fog at the station, whether on land or sea, not deeper than about 2 metres on land or 10 metres at sea
12	More or less continuous	
13	Lightning visible, no thunder heard	
14	Precipitation within sight, not reaching the ground or the surface of the sea	
15	Precipitation within sight, reaching the ground or the surface of the sea, but distant, i.e. estimated to be more than 5km from the station	
16	Precipitation within sight, reaching the ground or the surface of the sea, near to, but not at the station	
17	Thunderstorm, but no precipitation at the time of observation	
18	Squalls	} at or within sight of the station during the preceding hour or at the time of observation (* Tornado cloud or waterspout).
19	Funnel cloud(s)*	

WMO CODE TABLE 4677 (cont)

Code figure			Code figure		
20	Drizzle (not freezing) or snow grains	} not falling as shower(s)	70	Intermittent fall of snowflakes	} slight at time of observation
21	Rain (not freezing)		71	Continuous fall of snowflakes	
22	Snow		72	Intermittent fall of snowflakes	} moderate at time of observation
23	Rain and snow or ice pellets		73	Continuous fall of snowflakes	
24	Freezing drizzle or freezing rain		74	Intermittent fall of snowflakes	} heavy at time of observation
			75	Continuous fall of snowflakes	
25	Shower(s) of rain		76	Diamond dust (with or without fog)	
26	Shower(s) of snow, or of rain and snow		77	Snow grains (with or without fog)	
27	Shower(s) of hail, or of rain and hail		78	Isolated star-like snow crystals (with or without fog)	
28	Fog or ice fog		79	Ice pellets	
29	Thunderstorm (with or without precipitation)		80	Rain shower(s), slight	
30		} - has decreased during the preceding hour - no appreciable change during the preceding hour - has begun or has increased during the preceding hour - has decreased during the preceding hour	81	Rain shower(s), moderate or heavy)	
31	Slight or moderate dust-storm or sandstorm		82	Rain shower(s), violent	
32			83	Shower(s) of rain and snow mixed, slight	
33			84	Shower(s) of rain and snow mixed, moderate or heavy	
34	Severe duststorm or sandstorm	} - no appreciable change during the preceding hour - has begun or has increased during the preceding hour	85	Snow shower(s), slight	
35			86	Snow shower(s), moderate or heavy	
36	Slight or moderate drifting snow	} generally low (below eye level)	87	} Shower(s) of snow pellets or small hail, with or without rain or rain and snow mixed	- slight
37	Heavy drifting snow		88		- moderate or heavy
38	Slight or moderate blowing snow	} generally high (above eye level)	89	} Shower(s) of hail, with or without rain or rain and snow mixed, not associated with thunder	- slight
39	Heavy blowing snow		90		- moderate or heavy
40	Fog or ice fog at a distance at the time of observation, but not at the station during the preceding hour, the fog or ice fog extending to a level above that of the observer		91	Slight rain at time of observation	} thunderstorm during the preceding hour but not at time of observation
41	Fog or ice fog in patches		92	Moderate or heavy rain at time of observation	
42	Fog or ice fog, sky visible	} has become thinner during the preceding hour	93	Slight snow, or rain and snow mixed or hail at time of observation	
43	Fog or ice fog, sky invisible		94	Moderate or heavy snow, or rain and snow mixed or hail at time of observation	
44	Fog or ice fog, sky visible	} no appreciable change during the preceding hour	95	} Thunderstorm, slight or moderate, without hail, but with rain and/or snow at time of observation	} thunderstorm at time of observation
45	Fog or ice fog, sky invisible		96		
46	Fog or ice fog, sky visible	} has begun or has become thicker during the preceding hour	97	Thunderstorm, heavy, without hail, but with rain and/or snow at time of observation	
47	Fog or ice fog, sky invisible		98	Thunderstorm combined with dust-storm or sandstorm at time of observation	
48	Fog, depositing rime, sky visible		99	Thunderstorm, heavy, with hail at time of observation	
49	Fog, depositing rime, sky invisible				
50	Drizzle, not freezing, intermittent	} slight at time of observation			
51	Drizzle, not freezing, continuous				
52	Drizzle, not freezing, intermittent	} moderate at time of observation			
53	Drizzle, not freezing, continuous				
54	Drizzle, not freezing, intermittent	} heavy (dense) at time of observation			
55	Drizzle, not freezing, continuous				
56	Drizzle, freezing, slight				
57	Drizzle, freezing, moderate or heavy (dense)				
58	Drizzle and rain, slight				
59	Drizzle and rain, moderate or heavy				
60	Rain, not freezing, intermittent	} slight at time of observation			
61	Rain, not freezing, continuous				
62	Rain, not freezing, intermittent	} moderate at time of observation			
63	Rain, not freezing, continuous				
64	Rain, not freezing, intermittent	} heavy at time of observation			
65	Rain, not freezing, continuous				
66	Rain, freezing, slight				
67	Rain, freezing, moderate or heavy				
68	Rain or drizzle and snow, slight				
69	Rain or drizzle and snow, moderate or heavy				