

17798

XIth World Dredging Congress 1986, Brighton, UK, CEDA, Delft,
The Netherlands, 4-7 March 1986, p. 155-162.

LOCAL MAINTENANCE DREDGING BY MEANS OF A FIXED MUD PUMPING PLANT

by Jean E. Berlamont, Professor
Johan Van Goethem, Research Engineer
Hydraulics Laboratory
Catholic University of Leuven
de Croylaan 2
B-3030 HEVERLEE, Belgium

and E. Berleur, Director of research
S.B.B.M. - SIX CONSTRUCT
General Contractors
Mettewielaan 74-76
B-1080 BRUSSEL, Belgium



Vlaams Instituut voor de Zee
Flanders Marine Institute

INTRODUCTION

It has been suggested (Ref. 1, 3) that difficult and expensive local maintenance dredging in harbours, at a dock entrance, in front of a navigation lock, along quay walls, under pontoons and in small marinas may be substituted by installing a mud capture installation, provided with a fixed mud pumping plant.

STRATIFIED MUD DEPOSITS

It was shown earlier (Ref. 2) that homogeneous mud layers can easily be pumped up to densities of $\rho = 1150$ and even 1180 kg/m^3 , the slope of the water-mud interface being typically between $1/30$ and $1/50$. Such homogeneous mud layers may be present e.g. in ship channels, being considerably deeper than the surroundings, and into which mud flows from the estuary or the sea.

However, in other areas the mud enters with the flood, settles down at slack water and forms mud deposits of ever increasing thickness. Such stratified mud layers cannot be pumped with the same efficiency as homogeneous mud. The equilibrium slopes, in the vicinity of the suction heads of the pumps may become as large as $1/1$, which means that the "influence radius" of the pumps may be quite small.

Fig. 1 shows the results of pumping tests with homogeneous and with layered mud (curves A and B respectively).

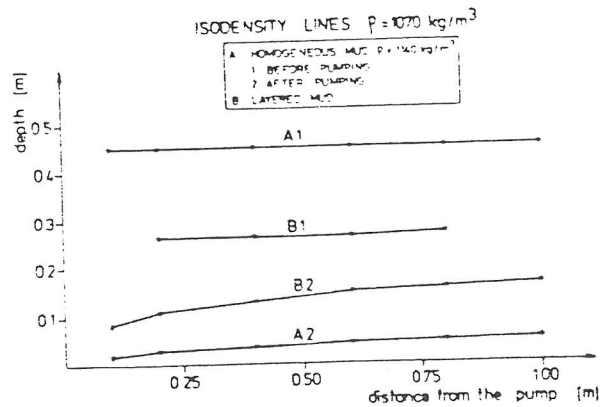

Figure 1 : Isodensity lines, $\rho = 1070 \text{ kg/m}^3$ for pumping tests with homogeneous and layered mud.

The tests were carried out in a $2,4 \times 2,4 \times 1,2 \text{ m}^3$ tank, in which the water level was kept constant at 1.0 m above the bottom. In case A homogeneous mud was used : the stirred mud was pumped into the tank up to a depth of 0.50 m . Thereafter the tank was filled (up to a depth of 1.0 m) with sea water. Care was taken to avoid the mixing of the mud with the water. After a consolidation period of 3 hours, density profiles were recorded with a γ -densimeter. From these records the isodensity line $\rho = 1070 \text{ kg/m}^3$ (curve A1 in Fig. 1) was derived, which represents in a way the mud-water interface. Just after pumping, new density profiles were recorded to obtain curve A2, which shows the amount of residual mud in the tank ($\rho > 1070 \text{ kg/m}^3$).

To study the behaviour of layered mud under pumping conditions, the sedimentation of mud out of a suspension at slack water was simulated by sprinkling every 2 hours, a quantity of mud ($\rho = 1080 \text{ kg/m}^3$) at the water surface, in such a way that a layered mud structure was built up. After a number of simulated tidal cycles, the resulting water mud interface ($\rho = 1070 \text{ kg/m}^3$) is curve B1 in Fig. 1 (derived from measured density profiles). The residual-mud water interface after pumping is represented by curve B2; in the case of layered mud (B) a volume of mud situated between curves A2 and B2 cannot be removed by pumping.

In these tests mud samples from the harbour of Zeebrugge and from the river Scheldt at Antwerp were used. In ref. (4) the authors present a comprehensive study of the characteristics of these muds. The variation of the yield stress τ_y [N/m^2] of mud (Ref. 4) with the density is given by the equation

$$\tau_y = A X^n \quad (\tau_y \text{ (N/m}^2))$$

In which A and n are characteristics of the mud and X the solids concentration (kg/m^3).

Origin of the mud	A	n	r correlation coefficient
Zeebrugge	7.9×10^{-8}	3.1	0.96
Antwerp 1	8.6×10^{-15}	5.5	0.98
Antwerp 2	6.2×10^{-9}	3.6	0.98

It was found that if the consolidation time T_c exceeds 3 hours, the yield stress increases strongly. Therefore it can be advantageous to limit the time interval between successive pumping actions to 3 hours.

Fig. 2 shows the evolution of the mud water interface after respectively 5 and 10 cycles of sedimentation (2 cm of mud, $\rho = 1080 \text{ kg/m}^3$ per cycle) and subsequent pumping.

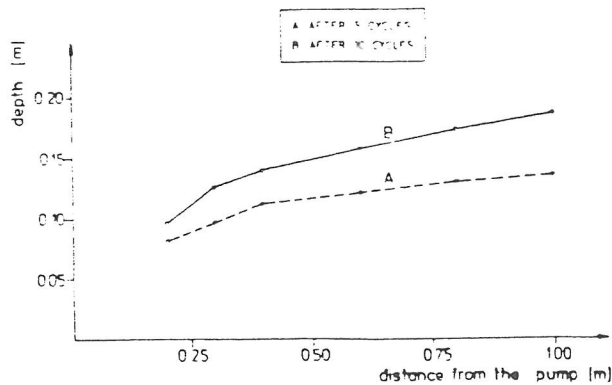

Figure 2 : Evolution of the mud-water interface during a laboratory test with sedimentation and subsequent pumping.

The authors have presented elsewhere (Ref. 2) a theoretical explanation for the building up of the bed in the presence of cyclic sedimentation out of a suspension, and regardless periodical mud pumping.

To increase the efficiency of the pumping, the stratified mud layers thus must be homogenized before pumping.

HOMOGENIZATION OF LAYERED MUD DEPOSITS

Different solutions are possible a priori and three of them were tried out both in the laboratory and in situ.

Water jetting

Laboratory tests with natural layered mud were carried out in the same tank as mentioned before, using a fixed circular head, provided with 8 jets (\varnothing 4 mm); the initial velocity at the orifices was of the order of 17.5 m/s. These tests showed that the water jetting was very efficient in removing the consolidated mud from the bottom and resuspending it, but only in a very narrow zone starting from the jet opening (photo 1).

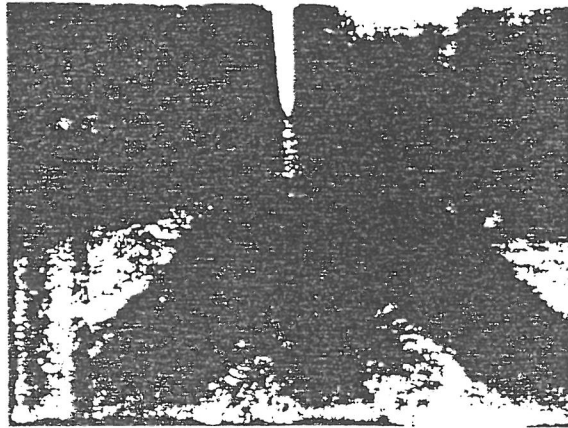

Photo 1 : Top view of the effect of water jetting on consolidated layered mud.

Roughly speaking, the jet is efficient over a width $b = 0.1 x$ (with x being the distance from the pump) where the velocity is higher than the critical velocity for mud erosion (Fig. 3), (Ref. 5). Clearly the solution of the problem could only be obtained by a rotating head. This was actually carried out several times at a site in Antwerp, resulting in an efficient clearing of the bottom, over a relatively small surface (Fig. 3). With a pump power of 75 kW, the influence zone had a radius of approximately 7 m. It was clear that 60 % of the pump power was lost in overcoming the friction losses in the pipes and hoses connecting the pumps to the waterjets (approx. 30 m, \varnothing 51 mm). Therefore, and because of the problems to be expected with moving parts under water (and in the mud), this method could not be accepted for a definitive solution.

Air bubble mattress

Because of the fact that the mud pumps in Antwerp (Belgium) were air-lift pumps (so called "mamouth pumps") and two powerful air compressors were thus available at the site, the idea was put forward to use an air bubble mattress to homogenize the mud. The mattress was built of polyethylene pipes (\varnothing 25 mm), arranged in a square pattern and

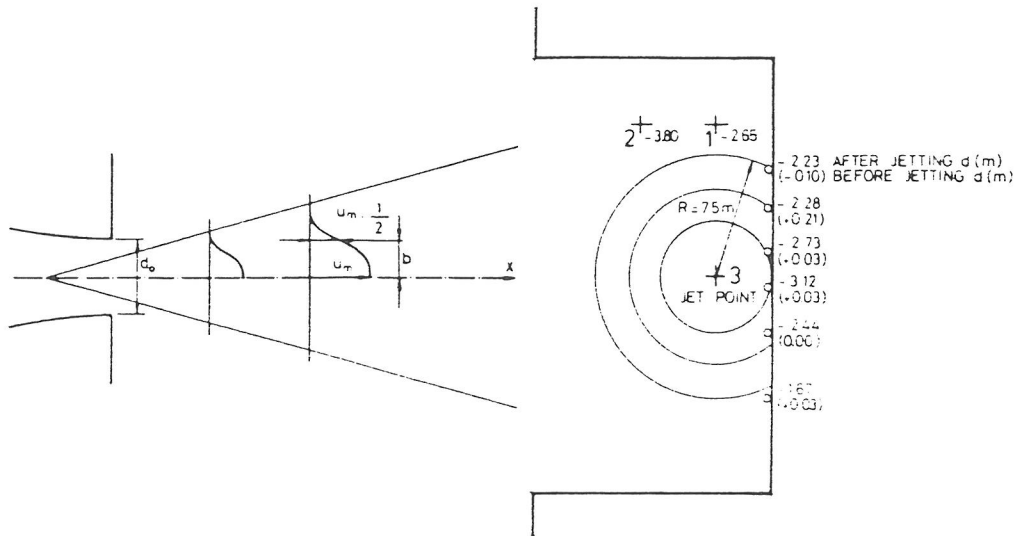

Figure 3a : Schematic figure of a circular jet (Ref. 5).

Figure 3b : Depth of the bottom in situ before and after clearing the bottom, using a manual rotating water jet.

provided with air jets every 40 cm. The mattress was laid on the bottom, lower than the suction head of the pump.

The system was tested in the laboratory and worked satisfactorily (Fig. 4). It was implemented on prototype scale under a pontoon in Antwerp and worked satisfactorily during a period of four months (Fig. 5).

The in situ test area covered about 77 m². Unfortunately only one check point was available above this area. However, a comparison of the depth measurements at that point with and without the air mattress shows the beneficial effect of the homogenisation with air bubbles (Fig. 5).

It was indeed possible to maintain a constant mud level with accurate regulation of the operating system.

The advantages of the system are :

- moderate energy consumption compared with water jetting
- cheap construction with easily available components.

It however has two important draw backs :

- the light, simple and cheap construction of the mattress makes it a vulnerable device, not suited for installation in navigation passes or along quay walls, where the propeller jet caused by a ship may destroy the mattress.
- the system is very vulnerable with respect to a power failure or a failure of the compressor or the pump. Indeed, if the system drops out, even for a few tidal cycles, the bed level builds up in the mean time. Once consolidated, this amount of mud cannot be removed afterwards. The equilibrium bed level thus mounts.

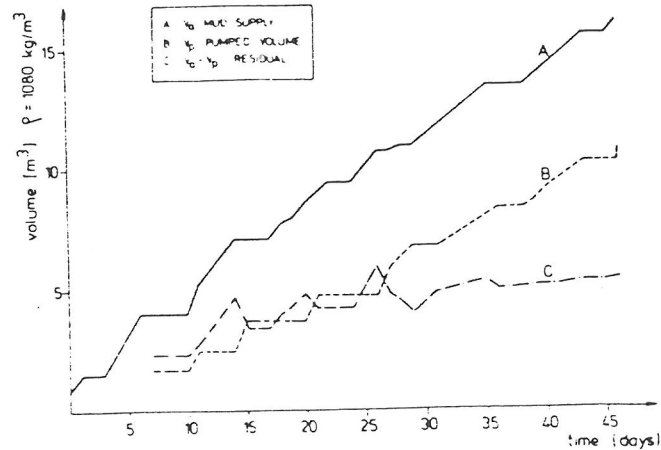

Figure 4 : Material balance for a laboratory pumping test using a fixed suction pump, in combination with an air mattress.

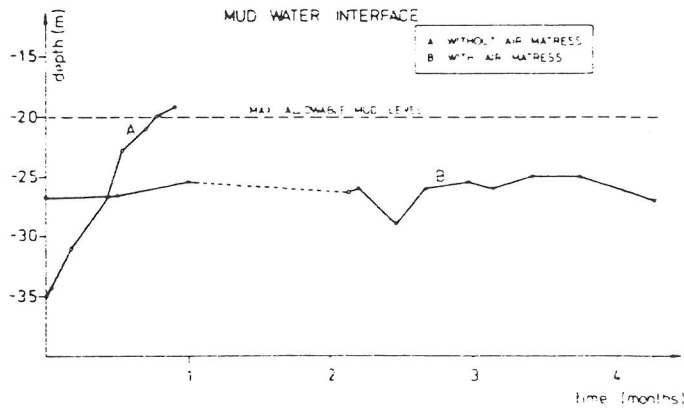

Figure 5 : Evolution of the bottom level under a pontoon in Antwerp.

Propeller mixers

An other way to bring into suspension "stiff" mud layers, and to homogenize them, is the use of propeller mixers. The propeller creates an horizontal water jet (Fig. 6). They have the same qualitative effect as water jets, but have the advantage to create water jets with much larger diameter and thus cleaning the bed over a large surface; moreover no power is lost due to friction loss in the pipes. Since 1985 such an equipment with a power demand of 15 kW, is operating succesfully in Antwerp (Fig. 7).

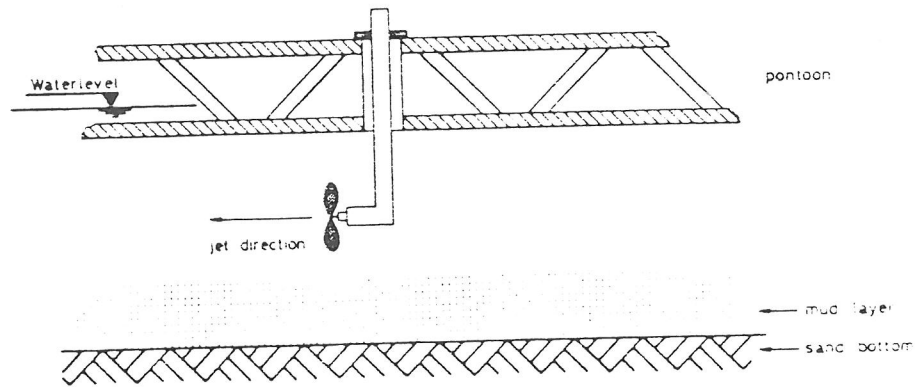

Figure 6 : Principle of the propeller system at Antwerp

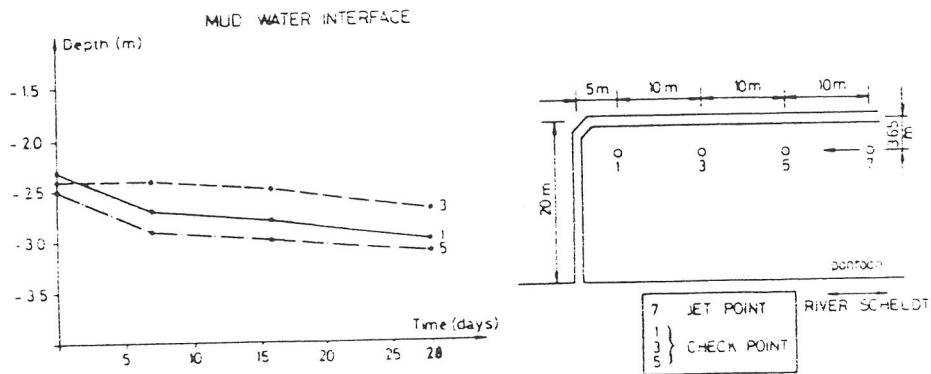

Figure 7 : Evolution of the bottom level under a pontoon in Antwerp in three check points.

If the location is situated close to a river channel where, at least during part of the tidal cycle, sufficient flow velocities exist, the different resuspending and homogenizing devices mentioned above, may be sufficient on their own. If however the resuspended mud cannot be removed by the currents, a mud pumping installation is necessary.

Since homogeneous or homogenized mud can be pumped very efficiently, such a fixed mud pumping plant may be very efficient.

CONCLUSIONS

It was shown, both in the laboratory and in situ, that homogeneous mud can easily be removed by a fixed mud pumping installation. If stratified mud deposits are homogenized before pumping e.g. using water jets, air jets mounted on a mattress underneath the suction head of the mud pumps, or propeller mixers, also these stratified muds can be pumped very efficiently.

Thus, eventually in combination with a mud homogenizing device, a fixed mud pumping plant may be an economic substitute for local maintenance dredging. The system is covered by international patent rights by S.R.B.M.-SIX CONSTRUCT, Belgium.

ACKNOWLEDGMENT

This research is partly granted by the I.W.O.N.L. (Belgian funds for supporting scientific research with industrial or agricultural application).

REFERENCES

1. "Mud Capture Installation at the sea lock of Zeebrugge" by J. Berlamont, M. Thienpont, Bo Verner, A. Van Bruwaene, L. Neyrinck, L. Maertens, Harbour Conference, Antwerp, Belgium 1983.
2. "A permanent mud pumping installation as an alternative for local maintenance dredging" by J. Berlamont, J. Van Goethem, E. Berleur, A. Van Bruwaene, 21th I.A.H.R. Congress, Melbourne, 1985.
3. "Maintenance Dredging Cost Minimization"; Joint Venture of the Ministry of Transport and Public Works 'Rijkswaterstaat' and the Municipality of Rotterdam, november 1983.
4. "Relations between Physico-chemical and rheological properties of fine-grained muds" by G. Verreet, J. Van Goethem, W. Viaene, J. Berlamont, R. Houthuys and E. Berleur, Third International Symposium on River Sedimentation, Jackson, Mississippi, 1986;
5. Rajaratnam, "Turbulent jets", 1976, p. 27-49, Elsevier, Amsterdam.